

建築設備用 **エスロン[®]パイプ[®]**

設計積算価格表 **2026年度版**

2026年5月20日価格改定

目次

●硬質塩化ビニルライニング鋼管・継手

- 1) エスロンLP 1
- 2) エスロンDVL 1
- 3) エスロンHTLP 1
- 4) エスロコートLX継手 1
- 5) エスロンUX継手 3

●水道用耐震型高性能ポリエチレン管・継手 (敷地内埋設管・建物給水管・消火設備配管用)

- 1) エスロハイパーAWパイプ 6
- 2) エスロハイパーAW継手 6
- 3) エスロハイパーAW
構造物耐震システム 9
- 4) エスロハイパーAW消火パイプ 9
- 5) エスロハイパーAW消火継手 10
- 6) エスロハイパーAW高圧消火パイプ 11
- 7) エスロハイパーAW高圧消火継手 11
- 8) エスロハイパーAWHPパイプ 12
- 9) エスロハイパーAWHP継手 12

●空調配管用高性能ポリエチレン管・継手

- 1) クウチョウハイパーCHパイプ 13
- 2) クウチョウハイパーCH継手 13

●地中熱利用システム

- 1) エスロヒート地中熱
〈ボアホール型・基礎杭型〉 15

●熱膨張耐火材 区画貫通テープ

- 1) フィブロック 16

●給水・給湯用架橋ポリエチレン管・継手

- 1) エスロペックス 17
- 2) エスロカチットS 17
- 3) ペックスヘッダー 19
- 4) ヘッダー 20
- 5) さや管ヘッダーシステム関連部材 21
- 6) 水圧テストプラグ 23
- 7) エスロンペックスエルボ 23
- 8) 配管化粧カバー 23

●給水・給湯・空調用

金属強化ポリエチレン管・継手

- 1) スーパーエスロメタックス 25
- 2) エスロンメタキュート 26
- 3) エスロンメタキュートRED 27
- 4) エスロンメタッチ 29
- 5) スーパーエスロメタックス用工具 30

●空調ドレン用結露防止層付

硬質塩化ビニル管・樹脂継手

- 1) エスロンACドレンパイプ 31
- 2) エスロンACドレン継手 31
- 3) エスロン透明ACドレン継手 32

●建物用耐火性硬質ポリ塩化ビニル管・継手

- 1) エスロン耐火VPパイプ 33
- 2) 耐火VPパイプ用遮音カバー 33
- 3) エスロン耐火DV継手 33
- 4) エスロン透明耐火DV継手 34
- 5) コンパクト掃除口付継手用
遮音カバー 35
- 6) エスロン耐火DV遮音継手 35
- 7) エスロン耐火ブラADミニ継手 36
- 8) エスロン耐火ブラAD継手
HG・SG 37

●給排水用硬質ポリ塩化ビニル管・継手

- 1) 水道用硬質ポリ塩化ビニル管 46
- 2) 一般用硬質ポリ塩化ビニル管 46
- 3) エスロン発泡三層パイプ 46
- 4) エスロン三層パイプ 46
- 5) エスロンカラーパイプ 46
- 6) エスロンHITS継手・ゴールド 47
- 7) エスロン金属入り
HI給水栓継手・ゴールド 48
- 8) エスロンTS継手 49
- 9) エスロン金属入り給水栓継手 50
- 10) エスロンHI継手透明ブルー 51
- 11) エスロンHI継手透明ブルー
(インサート付) 51
- 12) エスロンDV継手 52
- 13) エスロンDV継手付属品 53
- 14) エスロンDV-VU継手 53
- 15) エスロン大口径VU継手 54
- 16) エスロンVU特殊継手 54
- 17) エスロン自在継手 55
- 18) エスロン透明DV継手 55
- 19) エスロン透明DV-VU継手 56
- 20) エスロンDVカラー継手
[JIS K 6739] 56
- 21) エスロンDVカラー継手 57
- 22) エスロンDVココア継手 57
- 23) エスロン接着剤 58
- 24) エスロン滑剤 58
- 25) エスロン基礎貫通キット 59
- 26) エスロン雑排水専用合流継手 59

●給湯用硬質ポリ塩化ビニル管・継手

- 1) エスロンHTパイプ 60
- 2) エスロンHT継手 60
- 3) エスロンHTDV継手 62
- 4) エスロン透明HTDV継手 63
- 5) エスロンHTDV-VU継手 63
- 6) 食器洗浄機用耐熱排水配管セット 63
- 7) 耐熱ストレーナー付ホッパー 63
- 8) HT接着剤 63
- 9) 滑剤(DT-R及び差込ソケット用) 63

硬質塩化ビニルライニング鋼管・継手

1) エスロンLP (水道用硬質塩化ビニルライニング鋼管)[JWWA K 116]

品名	サイズ	品番	梱包数	価格(円/本)	改定	備考
SGP-VA(クロ) 長さ:4m/本 	15	LPB154	85	12,560	☆	
	20	LPB204	65	13,820	☆	
	25	LPB254	45	19,310	☆	
	32	LPB324	34	25,910	☆	
	40	LPB404	30	29,830	☆	
	50	LPB504	22	40,490	☆	
	65	LPB654	15	57,170	☆	
	80	LPB804	13	67,100	☆	
	100	LPB1H4	10	93,090	☆	
	125	LPB1Q4	7	114,400	☆	
	150	LPB1F4	5	156,000	☆	
SGP-VB(シロウ) 長さ:4m/本 	15	LPW154	85	14,830	☆	
	20	LPW204	65	16,490	☆	
	25	LPW254	45	22,930	☆	
	32	LPW324	34	30,740	☆	
	40	LPW404	30	35,240	☆	
	50	LPW504	22	48,100	☆	
	65	LPW654	15	67,750	☆	
	80	LPW804	13	79,500	☆	
	100	LPW1H4	10	110,380	☆	
	125	LPW1Q4	7	135,940	☆	
	150	LPW1F4	5	181,930	☆	

2) エスロンDVLP (排水用硬質塩化ビニルライニング鋼管)[WSP 042]

品名	サイズ	品番	梱包数	価格(円/本)	改定	備考
DVLP 長さ:5.5m/本 	40	DLP40N	25	36,250	☆	
	50	DLP50N	20	49,390	☆	
	65	DLP65N	15	69,520	☆	
	80	DLP80N	10	70,990	☆	
	100	DLP1HN	10	96,480	☆	
	125	DLP1QN	7	118,720	☆	
	150	DLP1FN	7	162,080	☆	
	200	DLP2HN	1	252,440	☆	
DVLP ハーフカット品 長さ:2.75m/本 	40	DLP402	25	19,720	☆	
	50	DLP502	20	26,620	☆	
	65	DLP652	15	37,420	☆	
	80	DLP802	10	38,880	☆	
	100	DLP1H2	10	51,270	☆	
	125	DLP1Q2	7	64,530	☆	
150	DLP1F2	7	88,160	☆		
200	DLP2H2	1	134,780	☆		





3) エスロンHTLP (給湯用硬質塩化ビニルライニング鋼管)[JWWA K 140]

品名	サイズ	品番	梱包数	価格(円/本)	改定	備考
HTLP 長さ:4m/本 	15	HLP154	55	8,150	☆	
	20	HLP204	45	10,220	☆	
	25	HLP254	30	15,030	☆	
	32	HLP324	21	21,070	☆	
	40	HLP404	18	25,260	☆	
	50	HLP504	14	34,300	☆	
	65	HLP654	10	53,800	☆	
	80	HLP804	7	65,530	☆	
	100	HLP1H4	5	91,420	☆	

4) エスロートLX継手

(水道用コア内蔵型ねじ込み式管端防食継手)[JPF MP 003]

(1) エスロートLX継手

品名	サイズ	品番	梱包数	価格(円/個)	改定	備考
エルボ(L) 	15	LXL15	120	630		
	20	LXL20	70	740		
	25	LXL25	40	1,170		
	32	LXL32	24	1,960		
	40	LXL40	20	2,380		
	50	LXL50	10	3,460		
	65	LXL65	10	6,680		
	80	LXL80	8	10,680		
	100	LXL1H	3	16,500		
	45°エルボ(45L) 	15	LX4L15	120	1,130	
20		LX4L20	70	1,220		
25		LX4L25	40	1,690		
32		LX4L32	30	2,360		
40		LX4L40	20	3,160		
50		LX4L50	10	4,340		
65		LX4L65	10	9,220		
80		LX4L80	8	12,520		
チーズ(T) 	15	LXT15	80	960		
	20	LXT20	50	1,110		
	25	LXT25	24	1,780		
	32	LXT32	18	2,680		
	40	LXT40	14	3,310		
	50	LXT50	8	4,680		
	65	LXT65	8	9,700		
	80	LXT80	6	14,460		
	100	LXT1H	2	23,380		
	ソケット(S) 	15	LXS15	160	740	
20		LXS20	90	830		
25		LXS25	50	1,200		
32		LXS32	40	1,640		
40		LXS40	30	1,990		
50		LXS50	20	2,890		
65		LXS65	20	5,570		
80		LXS80	18	7,520		
100		LXS1H	8	13,360		
ニップル(Ni) 		15	LXN15	180	660	
	20	LXN20	90	730		
	25	LXN25	50	950		
	32	LXN32	48	1,340		
	40	LXN40	35	1,690		
	50	LXN50	20	2,280		
	65	LXN65	20	4,250		
	80	LXN80	12	6,320		
プラグ(P) 	15	LXP15	500	820		
	20	LXP20	300	870		
	25	LXP25	180	950		
	32	LXP32	100	1,330		
	40	LXP40	80	1,720		
	50	LXP50	40	2,240		
	65	LXP65	30	3,950		
	80	LXP80	15	5,340		
フランジ(5KF) 	100	LXP1H	10	9,140		
	20	LXF20F	18	3,110		
	25	LXF25F	14	4,410		
	32	LXF32F	10	5,740		
	40	LXF40F	9	6,070		
	50	LXF50F	9	7,020		
	65	LXF65F	6	10,410		
	80	LXF80F	6	12,840		
100	LXF1HF	5	16,200			

4) エスロコートLX継手 (水道用コア内蔵型ねじ込み式管端防食継手)[JPF MP 003]

(1) エスロコートLX継手

品名	サイズ	品番	梱包数	価格(円/個)	改定	備考
	20	LXF20T	18	3,710		
	25	LXF25T	14	5,020		
	32	LXF32T	10	6,360		
	40	LXF40T	9	6,770		
	50	LXF50T	9	8,490		
	65	LXF65T	6	12,090		
	80	LXF80T	6	13,800		
	100	LXF1HT	5	17,670		
	125	LXF1QT	3	28,550		
	150	LXF1FT	2	31,980		
	15	LXU15	50	2,050		
	20	LXU20	40	2,630		
	25	LXU25	24	3,300		
	32	LXU32	12	4,340		
	40	LXU40	8	5,690		
	15	LXUP15	100	170		
	20	LXUP20	100	210		
	25	LXUP25	100	270		
	32	LXUP32	50	340		
	40	LXUP40	50	470		
	15	LXAL15	120	1,020		
	20	LXAL20	70	1,140		
	20×15	LXAL201	90	1,570		
	25	LXAL25	40	1,720		
	15	LXAS15	160	1,050		
	20	LXAS20	90	1,140		
	20×15	LXAS201	130	1,690		
	25	LXAS25	50	1,620		
	32	LXAS32	40	2,390		
	40	LXAS40	30	2,940		
	50	LXAS50	20	4,250		
	20×15	LXL201	90	1,040		
	25×20	LXL251	50	1,520		
	32×20	LXL322	35	2,450		
	32×25	LXL321	30	2,450		
	40×20	LXL403	25	3,570		
	40×25	LXL402	25	3,400		
	40×32	LXL401	20	3,400		
	50×40	LXL501	10	5,100		
	65×50	LXL651	6	12,550		
	80×65	LXL801	8	16,030		
	100×80	LXL1H1	4	27,800		

品名	サイズ	品番	梱包数	価格(円/個)	改定	備考
	20×15	LXS201	130	1,060		
	25×15	LXS252	70	1,330		
	25×20	LXS251	60	1,330		
	32×20	LXS322	50	1,730		
	32×25	LXS321	50	1,730		
	40×20	LXS403	30	2,380		
	40×25	LXS402	30	2,280		
	40×32	LXS401	30	2,280		
	50×20	LXS504	20	3,150		
	50×25	LXS503	20	3,150		
	50×32	LXS502	20	3,010		
	50×40	LXS501	20	3,010		
	65×20	LXS655	20	6,810		
	65×25	LXS654	20	6,810		
	65×32	LXS653	20	6,810		
	65×40	LXS652	20	6,470		
	65×50	LXS651	20	6,470		
	80×25	LXS805	18	9,180		
	80×40	LXS803	18	9,180		
	80×50	LXS802	18	8,740		
	80×65	LXS801	18	8,740		
	100×25	LXS1H6	8	16,060		
	100×40	LXS1H4	8	16,060		
	100×50	LXS1H3	8	16,060		
	100×65	LXS1H2	8	15,270		
	100×80	LXS1H1	8	15,270		
	20×15	LXT201	50	1,220		
	25×15	LXT252	40	1,780		
	25×20	LXT251	28	1,780		
	32×15	LXT323	25	3,050		
	32×20	LXT322	25	2,890		
32×25	LXT321	20	2,890			
40×15	LXT404	20	3,830			
40×20	LXT403	20	3,830			
40×25	LXT402	16	3,670			
40×32	LXT401	14	3,670			
50×15	LXT505	10	5,350			
50×20	LXT504	10	5,350			
50×25	LXT503	10	5,350			
50×32	LXT502	10	5,090			
50×40	LXT501	10	5,090			
65×20	LXT655	10	14,170			
65×25	LXT654	10	14,170			
65×32	LXT653	10	14,170			
65×40	LXT652	10	13,480			
65×50	LXT651	10	13,480			
80×20	LXT806	8	18,320			
80×25	LXT805	8	18,320			
80×32	LXT804	8	18,320			
80×40	LXT803	8	18,320			
80×50	LXT802	8	17,420			
80×65	LXT801	6	17,420			
100×20	LXT1H7	3	30,120			
100×25	LXT1H6	3	30,120			
100×32	LXT1H5	3	30,120			
100×40	LXT1H4	3	30,120			
100×50	LXT1H3	3	30,120			
100×65	LXT1H2	3	28,690			
100×80	LXT1H1	3	28,690			

4) エスロコートLX継手

(水道用コア内蔵型ねじ込み式管端防食継手) [JPF MP 003]

(2) エスロコートLX絶縁継手

品名	サイズ	品番	梱包数	価格(円/個)	改定	備考
絶縁給水栓エルボ (ISL) 	15	LISL15	50	2,340		
	20	LISL20	35	2,700		
	20×15	LISL201	35	3,640		
	25	LISL25	20	4,080		
	25×20	LISL251	20	5,260		
絶縁座付給水栓エルボ (IZSL) 	20×15	LIZL201	20	4,400		
絶縁給水栓ソケット (ISS) 	15	LISS15	70	2,510		
	20	LISS20	50	2,700		
	20×15	LISS201	50	3,540		
	25	LISS25	30	3,790		
	25×20	LISS251	30	4,690		
絶縁給水栓チーズ (IST) 	15	LIST15	40	3,110		
	20	LIST20	30	3,430		
	20×15	LIST201	30	4,440		
	25×20	LIST251	15	5,220		
絶縁メスオスエルボ (IMOL) 	20	NLIOL20	20	5,680		
絶縁メスオスソケット (IMOS) 	15	NLIOS15	50	4,840		
	20	NLIOS20	30	5,490		
	20×15	NLOS201	30	6,410		
	25	NLIOS25	20	8,200		
	32	NLIOS32	10	11,380		
	40	NLIOS40	8	14,170		
50	NLIOS50	5	16,600			

(3) エスロコートLX砲金継手

品名	サイズ	品番	梱包数	価格(円/個)	改定	備考
砲金製ニップル (NiH) 	15	NLXNH15	70	2,340		※
	20	NLXNH20	48	3,230		※
	25	NLXNH25	30	4,400		※
砲金製ブッシング (BuH) 	20×10	NLXB202	72	2,360		※
	20×15	NLXB201	72	2,360		※
	25×15	NLXB252	45	3,200		※
	25×20	NLXB251	45	3,200		※

※ 継手本体の材質は、JIS H 5121の青銅連鑄物6種 CAC406C(表面脱鉛処理品)です。

5) エスロンUX継手

(耐熱性硬質塩化ビニルライニング鋼管用管端防食継手) [JPF MP 005]











(1) エスロンUX継手

品名	サイズ	品番	梱包数	価格(円/個)	改定	備考
90°エルボ(L) 	15	LUTL15	120	430		
	20	LUTL20	60	540		
	25	LUTL25	30	850		
	32	LUTL32	20	1,390		
	40	LUTL40	16	1,770		
	50	LUTL50	10	2,650		
	65	LUTL65	6	5,680		
	80	LUTL80	5	8,010		
	100	LUTL1H	2	15,170		
45°エルボ(45L) 	15	LUT4L15	100	920		
	20	LUT4L20	50	940		
	25	LUT4L25	30	1,310		
	32	LUT4L32	25	1,660		
	40	LUT4L40	15	2,260		
	50	LUT4L50	10	3,430		
	65	LUT4L65	4	7,270		
	80	LUT4L80	3	9,920		
	100	LUT4L1H	3	16,860		

品名	サイズ	品番	梱包数	価格(円/個)	改定	備考
チーズ(T) 	15	LUTT15	70	570		
	20	LUTT20	35	740		
	25	LUTT25	20	1,340		
	32	LUTT32	12	2,030		
	40	LUTT40	10	2,450		
	50	LUTT50	5	3,650		
	65	LUTT65	4	8,350		
	80	LUTT80	2	11,450		
	100	LUTT1H	2	20,260		
	ソケット(S) 	15	LUTS15	120	480	
20		LUTS20	80	550		
25		LUTS25	40	800		
32		LUTS32	35	1,200		
40		LUTS40	20	1,420		
50		LUTS50	15	2,350		
65		LUTS65	6	4,230		
80		LUTS80	4	5,680		
100		LUTS1H	5	11,530		
ユニオン(U) 		15	LUTU15	40	2,040	
	20	LUTU20	30	2,650		
	25	LUTU25	20	3,310		
	32	LUTU32	18	4,270		
	40	LUTU40	10	5,530		
ユニオンパッキン 	15	LUTUP15	100	110		
	20	LUTUP20	100	160		
	25	LUTUP25	100	200		
	32	LUTUP32	50	250		
	40	LUTUP40	50	310		
	50	LUTUP50	30	390		
プラグ(P) 	15	LUTP15	180	650		
	20	LUTP20	120	670		
	25	LUTP25	70	740		
	32	LUTP32	45	1,040		
	40	LUTP40	36	1,340		
	50	LUTP50	12	1,780		
	65	LUTP65	8	2,550		
	80	LUTP80	6	3,180		
	100	LUTP1H	4	9,140		
	径違いエルボ(RL) 	20×15	LUTL201	80	810	
25×20		LUTL251	40	1,040		
32×25		LUTL321	25	1,880		
40×32		LUTL401	15	2,420		
50×40		LUTL501	10	3,450		
65×50		LUTL651	4	9,530		
80×65		LUTL801	3	12,700		
100×80		LUTL1H1	3	17,630		

5) エスロンUX継手 (耐熱性硬質塩化ビニルライニング鋼管用管端防食継手) [JPF MP 005]

(1) エスロンUX継手

品名	サイズ	品番	梱包数	価格(円/個)	改定	備考	
径違いチーズ(RT) 	20×15	LUTT201	40	960			
	25×15	LUTT252	20	1,310			
	25×20	LUTT251	20	1,310			
	32×15	LUTT323	25	2,150			
	32×20	LUTT322	16	2,030			
	32×25	LUTT321	16	2,030			
	40×15	LUTT404	20	2,770			
	40×20	LUTT403	15	2,770			
	40×25	LUTT402	15	2,650			
	40×32	LUTT401	10	2,650			
	50×15	LUTT505	10	4,020			
	50×20	LUTT504	8	4,020			
	50×25	LUTT503	8	4,020			
	50×32	LUTT502	8	3,850			
	50×40	LUTT501	8	3,850			
	65×20	LUTT655	4	8,860			
	65×25	LUTT654	4	8,860			
	65×32	LUTT653	4	8,860			
	65×40	LUTT652	4	8,420			
	65×50	LUTT651	4	8,420			
	80×20	LUTT806	3	12,640			
	80×25	LUTT805	3	12,640			
	80×32	LUTT804	3	12,640			
	80×40	LUTT803	3	12,640			
	80×50	LUTT802	3	12,040			
	80×65	LUTT801	2	12,040			
	100×20	LUTT1H7	3	23,400			
	100×25	LUTT1H6	3	23,400			
	100×32	LUTT1H5	3	23,400			
	100×40	LUTT1H4	3	23,400			
100×50	LUTT1H3	3	23,400				
100×65	LUTT1H2	3	22,280				
100×80	LUTT1H1	3	22,280				
径違いソケット(RS) 	20×15	LUTS201	90	800			
	25×15	LUTS252	40	1,040			
	25×20	LUTS251	40	1,040			
	32×20	LUTS322	45	1,280			
	32×25	LUTS321	40	1,280			
	40×20	LUTS403	30	1,680			
	40×25	LUTS402	25	1,620			
	40×32	LUTS401	25	1,620			
	50×20	LUTS504	20	2,740			
	50×25	LUTS503	20	2,740			
	50×32	LUTS502	15	2,620			
	50×40	LUTS501	15	2,620			
	65×40	LUTS652	5	6,070			
	65×50	LUTS651	5	6,070			
	80×50	LUTS802	4	8,620			
	80×65	LUTS801	4	8,620			
	100×50	LUTS1H3	4	12,680			
	100×65	LUTS1H2	4	12,080			
	100×80	LUTS1H1	4	12,080			
	プッシング(Bu) 	20×15	LUTB201	65	950		
25×20		LUTB251	50	1,160			
32×20		LUTB322	35	1,740			
32×25		LUTB321	35	1,740			
40×20		LUTB403	20	2,440			
40×25		LUTB402	20	2,330			
40×32		LUTB401	20	2,330			
50×20		LUTB504	18	3,210			
50×25		LUTB503	18	3,210			
50×32		LUTB502	18	3,060			
50×40		LUTB501	18	3,060			
65×32		LUTB653	5	5,220			
65×40		LUTB652	5	5,010			
65×50		LUTB651	5	5,010			
80×32		LUTB804	4	6,960			
80×40		LUTB803	4	6,960			
80×50		LUTB802	4	6,620			
80×65		LUTB801	4	6,620			
100×50		LUTB1H3	4	13,270			
100×65		LUTB1H2	4	12,630			
100×80		LUTB1H1	4	12,630			
10Kフランジ(10KF) 		20	LUTF20	12	3,270		
		25	LUTF25	12	4,700		
		32	LUTF32	14	5,780		
		40	LUTF40	12	6,350		
		50	LUTF50	10	7,770		
		65	LUTF65	6	11,180		
		80	LUTF80	6	12,310		
		100	LUTF1H	4	16,800		
5Kフランジ(5KF) 		20	LUTF20F	12	1,990		
		25	LUTF25F	12	2,910		
		32	LUTF32F	14	3,620		
		40	LUTF40F	12	4,350		
		50	LUTF50F	10	5,440		
		65	LUTF65F	6	8,500		
		80	LUTF80F	6	11,030		
	100	LUTF1HF	4	15,540			
ニップル(Ni) 	15	LUN115	120	480			
	20	LUN120	80	560			
	25	LUN125	40	740			
	32	LUN132	36	1,090			
	40	LUN140	25	1,290			
	50	LUN150	14	1,810			
	65	LUN165	6	3,860			
	80	LUN180	4	5,220			
	100	LUN1H	4	11,060			
	ロングニップル(LNi) 50L 	15	LUN156L	180	510		
20		LUN206L	150	570			
25		LUN256L	100	750			
ロングニップル(LNi) 75L 	32	LUN324L	35	1,140			
	40	LUN404L	30	1,340			
	50	LUN504L	15	1,680			
ロングニップル(LNi) 100L 	15	LUN153L	120	650			
	20	LUN203L	80	720			
	25	LUN253L	56	960			
	32	LUN323L	30	1,250			
	40	LUN403L	24	1,530			
	50	LUN503L	14	1,900			
	65	LUN653L	8	3,010			
	80	LUN803L	6	3,800			
ロングニップル(LNi) 150L 	15	LUN151L	80	830			
	20	LUN201L	55	850			
	25	LUN251L	35	1,140			
	32	LUN321L	20	1,560			
	40	LUN401L	15	1,870			
	50	LUN501L	10	2,350			
	65	LUN651L	6	3,750			
	80	LUN801L	5	4,700			
100	LUN1H1L	3	8,010				

5) エスロンUX継手

(耐熱性硬質塩化ビニルライニング鋼管用管端防食継手) [JPF MP 005]

(2) エスロンUX絶縁継手

品名	サイズ	品番	梱包数	価格(円/個)	改定	備考
絶縁給水栓エルボ (ISL) 	15	LUIL15	40	2,260		
	20	LUIL20	25	2,800		
	20×15	LUIL201	25	2,920		
	25	LUIL25	15	3,990		
	25×20	LUIL251	15	3,990		
絶縁給水栓ソケット (ISS) 	15	LUIS15	55	2,390		
	20	LUIS20	40	2,920		
	20×15	LUIS201	40	2,920		
	25	LUIS25	25	3,990		
	25×20	LUIS251	25	3,990		
絶縁給水栓チーズ (IST) 	15	LUIT15	30	2,920		
	20	LUIT20	25	3,360		
	20×15	LUIT201	25	3,480		
	25×20	LUIT251	10	4,000		
絶縁座付給水栓エルボ (IZSL) 	20×15	LUIZ201	15	3,990		
絶縁メスオスソケット (IMOS) 	15	NUMOS15	40	3,670		
	20	NUMOS20	25	4,310		
	25	NUMOS25	15	5,980		
	32	NUMOS32	7	10,570		
	40	NUMOS40	5	13,380		
	50	NUMOS50	3	15,370		

(3) エスロンUX砲金継手

品名	サイズ	品番	梱包数	価格(円/個)	改定	備考
砲金製ニップル (NiH) 	15	NLUNI15	70	1,070		
	20	NLUNI20	48	1,200		
	25	NLUNI25	30	1,970		
砲金製ブッシング (BuH) 	20×15	NLUB201	72	1,530		
	25×15	NLUB252	45	2,040		
	25×20	NLUB251	45	2,040		
	32×15	NLUB323	36	3,040		
	32×20	NLUB322	36	3,040		

1) エスロハイパー-AW パイプ

(水道用耐震型高性能ポリエチレン管) [PWA001/005規格品・準拠品]

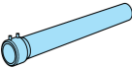
品名	サイズ	品番	梱包数	価格(円/本)	改定	備考
プレーンエンド直管 長さ: 3,120mm 	20	AW203	10	1,320		○
	25	AW253	10	1,690		○
	30	AW303	10	2,350		○
	40	AW403	5	3,380		○
	50	AW503	5	4,700		○
	65	AW653	2	7,720		
	75	AW753	2	9,970		
プレーンエンド直管 長さ: 5,000mm 	20	AW205	10	2,210		○
	25	AW255	10	2,780		○
	30	AW305	10	3,860		○
	40	AW405	5	5,510		○
	50	AW505	5	7,680		○
	65	AW655	2	12,320		
	75	AW755	2	16,580		
	100	AW1H5	2	24,850		
	125	AW1Q5	1	37,370		
	150	AW1F5	1	42,700		
EF受口付直管 有効長: 5,000mm 	75	AWK755	2	23,660		
	100	AWK1H5	2	36,720		
	150	AWK1F5	1	64,300		
	200	AWK2H5	1	120,300		
枝付EF片受直管 有効長: 3,200mm 	25×20	AWE251	2	11,880		○
	30×20	AWE302	2	12,450		○
	40×20	AWE403	2	16,410		○
	50×20	AWE504	2	18,460		○
	65×20	AWE655	2	29,280		
	75×20	AWE756	2	40,580		
	30×25	AWE301	2	12,710		○
	40×25	AWE402	2	16,700		○
	50×25	AWE503	2	18,830		○
	65×25	AWE654	2	29,690		
コイル管 	20	AW2030	1	12,870		※○
	25	AW2530	1	16,310		※○

※ 受注生産品です。

○ ストライプライン付きです。
プレーンエンド直管の呼び径65~200は2026年下期以降に
順次ストライプライン付きに切り替え予定です。
品番は従来品と同じです。

2) エスロハイパー-AW 継手

(水道用耐震型高性能ポリエチレン管用継手) [PWA002/006規格品・準拠品]





品名	サイズ	品番	梱包数	価格(円/個)	改定	備考
EFソケット 	20	KES20WK	144	1,850		
	25	KES25WK	120	2,150		
	30	KES30WK	72	2,230		
	40	KES40WK	48	2,760		
	50	KES50K	32	2,980		
	65	KES65	20	4,480		
	75	HES75N	24	5,610		
	100	HES1HN	12	9,390		
	125	HES1Q	3	13,550		
	150	HES1FN	4	16,340		
	200	HES2HI	1	37,210		

**エスロハイパー-AWが
ストライプライン付きに変わります!**

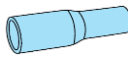

第一弾
呼び径20~50から
順次切り替え!







エスロハイパー-AW HPも
呼び径20~50から
順次切り替え!

品名	サイズ	品番	梱包数	価格(円/個)	改定	備考
レデューサ 	30×20	KSRS302	128	1,450		
	40×20	KSRS403	84	1,570		
	40×25	KSRS402	84	1,640		
	50×20	KSRS504	60	1,940		
	50×25	KSRS503	60	1,940		
	65×50	HSRS651	25	7,260		
	75×50	HSRS752	20	7,990		
	75×65	HSRS751	16	8,950		
	100×75	HSRS1H1	8	9,610		
	125×100	HSRS1Q1	4	10,770		
	150×100	HSRS1F2	2	14,780		
	150×125	HSRS1F1	2	17,670		
	200×150	HSRS2H1	2	23,800		
EF片受レデューサ 	75×50	HKRS752	2	18,880		
	100×75	HKRS1H1	2	22,810		
	150×100	KRS1F2M	2	36,690		
	200×150	KRS2H1N	1	66,670		※
EFチーズ 	20×20	KET20K	64	5,240		
	25×20	KET251K	40	5,370		
	25×25	KET25WK	64	5,620		
	30×20	KET302K	32	5,510		
	30×25	KET301K	32	5,640		
	30×25×20	KET312K	32	5,420		
	30×30	KET30K	40	5,840		
	40×20	KET403K	28	7,220		
	40×25	KET402K	28	7,340		
	40×30	KET401K	20	7,600		
	40×30×20	KET413K	28	7,100		
	40×40	KET40K	20	7,840		
	50×20	KET504K	20	8,130		
	50×25	KET503K	20	8,260		
	50×30	KET502K	16	8,590		
	50×40	KET501K	16	8,830		
	50×40×20	KET514K	20	7,980		
	50×50	KET50WK	16	9,360		
	65×20	KET655	16	8,650		
	65×25	KET654	16	8,780		
	65×30	KET653	12	8,960		新
	65×40	KET652	11	9,140		新
	65×50	KET651	10	9,320		
65×65	KET65	10	9,440			
75×20	HET756	8	9,410			
75×25	HET755	8	9,540			
75×30	HET754	8	9,630		新	
75×40	HET753	7	9,710			
75×50	HET752N	7	9,820			
75×65	HET751	6	10,000		新	
75×75	HET75N	6	10,030			
100×50	HET1H3N	4	13,410			
100×65	HET1H2	4	18,800		新	
100×75	HET1H1N	4	24,170			
100×100	HET1HN	4	25,090			
EFレデューサ 	25×20	KRS251K	96	1,930		
	30×25	KRS301K	72	2,330		
	40×30	KRS401K	48	4,020		
	50×20	KRS504K	6	近日発売予定	新	
	50×25	KRS503K	6	近日発売予定	新	
	50×30	KRS502K	32	4,410		
50×40	KRS501K	32	5,960			

※ 受注生産品です。

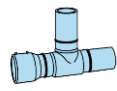
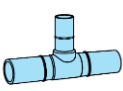
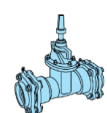
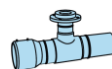
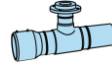
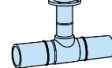
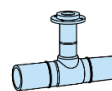
2)エスロハイパーAW 継手

(水道用耐震型高性能ポリエチレン管用継手)[PWA002/006規格品・準拠品]

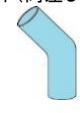
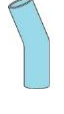
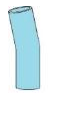









品名	サイズ	品番	梱包数	価格(円/個)	改定	備考	
	25×20	KT251LK	28	7,110		○	
	30×20	KET32LK	18	7,250		○	
	30×25×20	KT312LK	18	7,180			
	40×20	KET43LK	15	8,930		○	
	40×25	KET42LK	15	9,170		○	
	40×30×20	KT413LK	15	8,790			
	50×20	KET54LK	12	9,870		○	
	50×25	KET53LK	12	10,040		○	
	50×40×20	KT514LK	12	9,740			
	20	KEL20WK	72	2,260			
	25×20	KEL251K	48	2,390			
	25	KEL25WK	48	2,390			
	30	KEL30WK	48	2,460			
	40	KEL40WK	32	4,290			
	50	KEL50MK	24	5,010			
	65	KEL65	15	7,620			
	75	HEL75	8	9,720			
	100	HEL1H	4	18,150			
	20	KE4L20K	84	2,210			
	25	KE4L25K	72	2,330			
	30	KE4L30K	32	2,530			
	40	KE4L40K	24	4,090			
	50	KE4L50K	24	4,840			
	65	KE4L65	18	7,500			
	75	HE4L75N	12	9,440			
	100	HE4L1H	4	17,670			
		125×50	HKT1Q4	1			新
125×65		HKT1Q3	1	近日発売予定		新	
125×75		HKT1Q2	1			新	
150×50		HKT1F5	1	83,700			
150×65		HKT1F4	1	83,700			
150×75		HKT1F3M	1	86,320			
150×100		HKT1F2M	1	86,830			
150×125		HKT1F1	1	近日発売予定		新	
150×150		HKT1FM	1	89,110			
200×50		HKT2H6	1	116,800		※	
200×65		HKT2H5	1	116,800		※	
200×75		HKT2H4N	1	130,770		※	
200×100		HKT2H3N	1	133,560		※	
200×125		HKT2H2	1	135,990		新	
200×150		HKT2H1N	1	138,410		※	
200×200		HKT2HN	1	142,480		※	
		125×50	HSPT1Q4	1	33,300		
		125×65	HSPT1Q3	1	33,300		
	125×100	HSPT1Q1	1	34,360			
	125×125	HSPT1Q	1	35,700			
	150×75	HSPT1F3	1	68,340		※	
	150×100	HSPT1F2	1	68,870		※	
	150×150	HSPT1F	1	71,140		※	
	200×75	HSPT2H4	1	89,840		※	
	200×100	HSPT2H3	1	92,630		※	
	200×150	HSPT2H1	1	97,490		※	
	200×200	HSPT2H	1	101,550		※	
	50右開	SSS50R	1	124,290	☆	※	
	50左開	SSS50L	1	124,290	☆	※	
	75右開	SSS75R	1	155,390	☆	※	
	75左開	SSS75L	1	155,390	☆	※	
	100右開	SSS1HR	1	193,780	☆	※	
	100左開	SSS1HL	1	193,780	☆	※	
	150右開	SSS1FR	1	324,920	☆	※	
	150左開	SSS1FL	1	324,920	☆	※	
	150×75	HF1F3MJ	1	103,980			
	150×100	HF1F2MJ	1	111,220			
	200×75	HFT2H4J	1	140,620		※	
	200×100	HFT2H3J	1	145,350		※	
		150×75	HF1F3MT	1	103,980		
		150×100	HF1F2MT	1	111,220		※
		200×75	HFT2H4S	1	140,620		※
		200×100	HFT2H3S	1	145,350		
		75×75	SFT75J	1	24,710		※
		100×75	SFT1H1J	1	28,560		※
		100×100	SFT1HJ	1	36,950		※
		150×75	SFT1F3J	1	86,010		※
150×100		SFT1F2J	1	93,250		※	
200×75		SFT2H4J	1	99,680		※	
200×100		SFT2H3J	1	104,420		※	
	75×75	SFT75T	1	24,710		※	
	100×75	SFT1H1T	1	28,560		※	
	100×100	SFT1HT	1	36,950		※	
	150×75	SFT1F3T	1	86,010		※	
	150×100	SFT1F2T	1	93,250		※	
	200×75	SFT2H4T	1	99,680		※	
	75×75	HFT75J	1	27,430			
	100×75	HFT1H1J	1	31,790			
	100×100	HFT1HJ	1	41,000		※	
	75×75	HFT75S	1	27,430			
	100×75	HFT1H1S	1	31,790			
	100×100	HFT1HS	1	41,000		※	
	75分岐用	TSD75	1	50,320		☆	
	100分岐用	TSD1H	1	50,320		☆	
	50	HS9B50	10	10,000		○	
	75	HS9B75	5	10,200			
	100	HS9B1H	2	15,850			
	150	HS9B1F	2	35,280			
	200	HS9B2H	1	76,840			
	50	HS4B50	10	8,940		○	
	75	HS4B75	5	9,560			
	100	HS4B1H	5	15,470			
	150	HS4B1F	2	27,310			
	50	HS2B50	10	8,250		○	
	75	HS2B75	5	8,700			
	100	HS2B1H	5	13,840			
	150	HS2B1F	2	23,340			
	200	HS2B2H	1	48,550			
	50	HS1B50	10	7,570		○	
	75	HS1B75	5	8,130			
	100	HS1B1H	5	12,420			
	150	HS1B1F	2	20,980			
	200	HS1B2H	1	44,220			

○ ストライプライン付きです。











※ 受注生産品です。

2)エスロハイパーAW 継手

(水道用耐震型高性能ポリエチレン管用継手)[PWA002/006規格品・準拠品]

品名	サイズ	品番	梱包数	価格(円/個)	改定	備考	
EF片受90°バンド 	75	HK9B75N	2	21,690			
	100	HK9B1HN	2	30,860			
	150	HK9B1FM	1	59,630			
	200	HK9B2HN	1	107,050			
EF片受45°バンド 	75	HK4B75N	2	20,850			
	100	HK4B1HN	2	25,330			
	150	HK4B1FM	2	50,700			
	200	HK4B2HN	1	101,350			
EF片受22 1/2° バンド 	75	HK2B75N	2	19,680			
	100	HK2B1HN	2	23,690			
	150	HK2B1FM	2	46,270			
	200	HK2B2HN	1	92,040			
EF片受11 1/4° バンド 	75	HK1B75N	2	18,410			
	100	HK1B1HN	2	22,290			
	150	HK1B1FM	2	43,620			
	200	HK1B2HN	1	87,570			
45°ショートバンド 	50	HS4L50	36	3,870			
	75	HS4L75	16	9,560		※	
	100	HS4L1H	2	15,470		※	
	125	HS4L1Q	2	19,600		※	
	150	HS4L1F	2	27,310		※	
	200	HS4L2H	1	48,400			
90°ショートバンド 	50	HS9L50	36	3,990			
	75	HS9L75	12	10,200		※	
	100	HS9L1H	2	16,090			
	125	HS9L1Q	2	23,110			
	150	HS9L1F	2	35,280			
	200	HS9L2H	1	59,860			
Sバンド(両差し H=450) ※200のみH=500 	75	HSSB75	3	17,570			
	100	HSSB1H	2	26,830			
	150	HSSB1F	1	56,910			
	200	HSSB2H	1	124,060			
EF片受Sバンド(H=450) ※200のみH=500 	75	HKSB75N	1	31,640			
	100	HKSB1HN	1	44,020			
	150	HKSB1FM	1	83,850			
	200	HKSB2HN	1	169,940			
EFキャップ 	20	KEC20K	180	1,520			
	25	KEC25WK	128	1,660			
	30	KEC30K	120	3,000			
	40	KEC40K	64	5,140			
	50	KEC50WK	40	5,530			
	75	HEC75N	21	6,990			
SPキャップ 	100	HSC1H	2	11,790			
	150	HSC1F	1	19,880			
フランジ短管 G形 JIS10K 	40	KFS40N	1	15,970			
	50	HFS50N	1	16,250			
	65	HFS65N	1	17,550			
	75	HFS75J	1	18,360			
	100	HFS1HJ	1	22,530			
	125	HFS1QJ	1	32,550			
	150	HFS1FJ	1	36,700			
	200	HFS2HJ	1	49,780		※	

※ 受注生産品です。

品名	サイズ	品番	梱包数	価格(円/個)	改定	備考	
フランジ短管 F形 JIS10K 	40	KFS40RN	1	15,970			
	50	HFS50RN	1	16,250			
	65	HFS65RN	1	17,550			
	75	HSF75T	1	18,360			
	100	HSF1HT	1	22,530			
	125	HSF1QT	1	32,550			
	150	HSF1FT	1	36,700			
	200	HSF2HT	1	49,780		※	
フランジ短管 G形 7.5K 	50	HFS50N	1	16,250			
	75	HFS75	1	18,360			
	100	HFS1H	1	22,530			
	150	HFS1F	1	36,700			
フランジ短管 F形 7.5K 	50	HFS50RN	1	16,250			
	75	HSF75R	1	18,360			
	100	HSF1HR	1	22,530			
	150	HSF1FR	1	36,700			
フランジ短管 F形 7.5K 	200	HSF2HR	1	49,780		※	
EFフランジ短管 G形 JIS10K 	75	HKF75J	1	32,700			
	100	HKF1HJ	1	43,790			
	150	HKF1FMJ	1	56,660			
	200	HKF2HJ	1	79,320		※	
EFフランジ短管 F形 JIS10K 	75	HKF75T	1	32,700			
	100	HKF1HT	1	43,790			
	150	HKF1FMT	1	56,660			
	200	HKF2HT	1	79,320		※	
EFフランジ短管 G形 7.5K 	75	HKF75	1	32,700			
	100	HKF1H	1	43,790			
	150	HKF1FM	1	56,660			
	200	HKF2H	1	79,320		※	
EFフランジ短管 F形 7.5K 	75	HKF75R	1	32,700			
	100	HKF1HR	1	43,790			
	150	HKF1FMR	1	56,660			
	200	HKF2HR	1	79,320		※	
EFサドル 	50×25	KBS503H	24	8,770			
	75×20	HBS756H	16	9,740			
	75×25	HBS755H	16	10,340			
	75×50	HBS752N	8	22,670			
	100×20	HBS1H7H	12	9,980			
	100×25	HBS1H6H	12	10,480			
	100×50	HBS1H3N	8	23,380			
	150×20	HBS1F9H	12	10,910			
	150×25	HBS1F8H	12	11,230			
	150×50	HBS1F5N	4	25,160			
	200×50	HBS2H6N	4	25,670			
EFサドル付分水栓 	50×20	EVS504N	2	25,150		※	
	50×25	EVS503N	2	27,890		※	
	75×20	EVS756N	2	35,700		※	
	75×25	EVS755N	2	40,870		※	
	75×30	EVS754N	1	68,960		※	
	75×40	EVS753N	1	76,530		※	
	75×50	EVS752N	1	84,080		※	
	100×20	EVS1H7N	1	37,490		※	
	100×25	EVS1H6N	1	42,900		※	
	100×30	EVS1H5N	1	69,670		※	
	100×40	EVS1H4N	1	77,300		※	
	100×50	EVS1H3N	1	84,940		※	
T形サドル 	50×25	HTSD503	32	4,280			
	50×30	HTSD502	32	4,580			
	75×25	HTSD755	24	4,360			
	75×30	HTSD754	24	4,660			
	100×30	HTSD1H5	12	5,200			

2) エスロハイパー-AW 継手 (水道用耐震型高性能ポリエチレン管用継手)
[PWA002/006規格品・準拠品]

品名	サイズ	品番	梱包数	価格(円/個)	改定	備考	
EFスクルージョイント オネジソケット コア内蔵バルブ対応 	20	KEOS20K	30	6,010	☆		
	25	KOSC25K	16	7,280	☆		
	30	KOSC30K	12	10,530	☆		
	40	KOSC40K	10	13,770	☆		
	50	KOSC50K	6	16,080	☆		
	65	KOSC65	5	22,970	☆		
	75	HOSC75	2	48,880	☆		
EFスクルージョイント メネジソケット 	20	KEMS20K	30	6,450	☆		
	25	KEMS25K	16	8,480	☆		
	30	KEMS30K	12	13,160	☆		
	40	KEMS40K	10	16,230	☆		
	50	KEMS50K	6	17,660	☆		
	50 × Rc3/4	KEMS504	8	17,830	☆		
	50 × Rc1	KEMS503	8	17,830	☆		
EFスクルージョイント ユニオンソケット 	20	KEUS20K	30	6,540	☆		
	25	KEUS25K	16	8,190	☆		
	30	KEUS30K	12	14,820	☆		
	40	KEUS40K	12	18,550	☆		
	50	KEUS50K	8	22,540	☆		
EFスクルージョイント エラスジョイント 	20	KEER20K	24	7,970	☆		
	25	KEER25K	15	9,910	☆		
EFスクルージョイント 給水栓ソケット 	20	KEKS20K	30	6,300	☆		
AW媒介継手 オネジソケット 	20	HAWB20	80	2,780	☆		
	25	HAWB25	60	4,170	☆		
AW媒介継手 メネジソケット 	20	HAWBM20	80	3,000	☆		
AW媒介継手 メネジ付エルボ 	20	AW9LM20	32	5,290	☆		
メタッチAW媒介継手 	20	MTAW20	36	6,900	☆		
メタッチAW媒介継手 エルボ 	20	MTAWL20	24	7,560	☆		
かんたんクランプ 	20	KCLMP20	50	70			
	25	KCLMP25	40	70			
	30	KCLMP30	30	80			
	40	KCLMP40	25	100			
	50	KCLMP50	15	110			

3) エスロハイパー-AW 構造物耐震システム

品名	サイズ	品番	梱包数	価格(円/セット)	改定	備考
標準穿孔タイプ 	50	ATSH50	1	139,150		※
	75	ATSH75	1	145,200		※
	100	ATSH1H	1	151,250		※
浅穿孔タイプ 	50	ATSS50	1	169,400		※
	75	ATSS75	1	175,450		※
	100	ATSS1H	1	181,500		※

4) エスロハイパー-AW消火パイプ (消火設備配管用高性能ポリエチレン管)

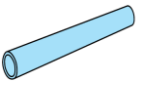
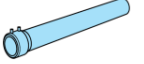
品名	サイズ	品番	梱包数	価格(円/本)	改定	備考
プレーンエンド直管 長さ: 5,000mm 	50	FPE505	5	6,970		
	65	FPE655	2	11,200		
	75	FPE755	2	14,420		
	100	FPE1H5	2	21,600		
	125	FPE1Q5	1	32,490		
	150	FPE1F5	1	37,130		※
EF受口付直管 長さ: 5,000mm 	200	FPE2H5	1	61,810		※
	75	FKP755	2	20,570		
	100	FKP1H5	2	31,920		
	150	FKP1F5	1	55,900		
	200	FKP2H5	1	104,600		※

※ 受注生産品です。

消火設備配管用高性能ポリエチレン管

エスロハイパー-AW消火管・継手



呼び径50~200で日本消防設備安全センターの性能認定取得













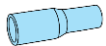







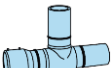

認定書

呼び径	認定番号
50	PL-032号
NEW 65	PL-056号
75	PL-024-1号, 2号
100	PL-023-1号, 2号
NEW 125	PL-059号
150	PL-025-1号, 2号
200	PL-036号

性能認定品以外の品種を使用する場合は、消防法施行令第32条による申請が必要となります。給水用のエスロハイパー-AWとは品番が異なりますのでご注意ください。



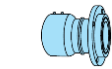



5) エスロハイパー-AW消火 継手 (消火設備配管用高性能ポリエチレン管用継手)

品名	サイズ	品番	梱包数	価格(円/個)	改定	備考
	50	FES50	40	2,740		
	65	FES65	20	4,480		
	75	FES75	24	5,610		
	100	FES1H	12	9,390		
	125	FES1Q	3	13,550		
	150	FES1F	4	16,340		
	200	FES2HI	1	37,210		※
	50	FEL50	30	4,760		
	65	FEL65	15	7,620		
	75	FEL75	8	9,720		
	100	FEL1H	4	18,150		
	50	FE4L50	36	4,600		
	65	FE4L65	18	7,500		
	75	FE4L75	12	9,440		
	100	FE4L1H	4	17,670		
	65×50	FSRS651	25	7,260		
	75×50	FSRS752	20	7,990		
	75×65	FSRS751	16	8,950		
	100×75	FSRS1H1	8	9,610		※
	125×100	FSRS1Q1	4	10,770		
	150×100	FSRS1F2	2	14,780		※
	100×75	FKRS1H1	2	22,810		※
	200×150	FKRS2H1	1	66,670		※
	125	FS45L1Q	2	19,600		
	125	FS9L1Q	2	23,110		
	150	FS9L1F	2	35,280		※
	200	FS9L2H	1	59,860		※
	50	FS9B50	10	10,000		
	75	FS9B75	5	10,200		※
	100	FS9B1H	2	15,850		※
	150	FK9B1F	1	59,630		※
	50×50	FET50	20	9,120		
	65×50	FET651	10	9,320		
	65×65	FET65	10	9,440		
	75×50	FET752	7	9,820		
	75×75	FET75	6	10,030		※
	100×50	FET1H3	4	13,410		
	100×65	FET1H2	1	30,860		
	100×75	FET1H1	4	24,170		※
	100×100	FET1H	4	25,090		※
	125×100	FSPT1Q1	1	34,360		
	125×125	FSPT1Q	1	35,700		
	150×75	FKT1F3	1	86,320		※
	150×150	FKT1F	1	89,110		※
	200×200	FKT2H	1	142,480		※

品名	サイズ	品番	梱包数	価格(円/個)	改定	備考
	75×75	FFT75J	1	27,430		※
	100×75	FFT1H1J	1	31,790		※
	75×75	FMT75J	1	26,620		※
	100×75	FMT1H1J	1	30,860		※
	50	FEC50	48	5,410		
	75	FEC75	21	6,990		※
	100	FSC1H	2	11,790		
	150	FSC1F	1	19,880		
	50	FFS50	1	16,250		
	65	FFS65	1	17,550		
	75	FFS75J	1	18,360		※
	100	FFS1HJ	1	22,530		※
	125	FFS1QJ	1	32,550		
	150	FFS1FJ	1	36,700		※
	50	FMS50	1	14,640		
	65	FMS65	1	15,850		
	75	FMS75J	1	16,580		※
	100	FMS1HJ	1	20,330		※
	125	FMS1QJ	1	29,400		
	150	FMS1FJ	1	33,030		※
	50	FSF50R	1	16,250		
	65	FFS65R	1	17,550		
	75	FSF75T	1	18,360		
	100	FSF1HT	1	22,530		
	125	FSF1QT	1	32,550		
	200	FSF2HT	1	49,780		※
	50	FSM50R	1	14,640		
	65	FMS65R	1	15,850		
	75	FSM75T	1	16,580		
	100	FSM1HT	1	20,330		
	125	FSM1QT	1	29,400		
	75	FKF75J	1	32,700		
	150	FKF1FJ	1	56,660		※
	75	FKM75J	1	31,100		
	150	FKM1FJ	1	53,850		※

※ 受注生産品です。

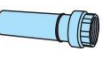
5) エスロハイパー-AW消火 継手
(消火設備配管用高性能ポリエチレン管用継手)











品名	サイズ	品番	梱包数	価格(円/個)	改定	備考
EFフランジ短管 F形 JIS10K 材質:SUS 	150	FKF1FT	1	56,660		
EFフランジ短管 F形 JIS10K 材質:SS400 	150	FKM1FT	1	53,850		
消火栓用フランジ短管 (F形 JIS10K, 65フランジ接続用) 材質:SUS 	75 × 65	FSF75TS	1	18,360		※
消火栓用フランジ短管 (F形 JIS10K, 65フランジ接続用) 材質:SS400 	75 × 65	FSM75TS	1	16,580		※
SPスクレージョイント (メネジ) 	100	FSPSC1H	1	80,960	☆	
EFスクレージョイント メネジソケット 	50 × Rc1	FEMS503	6	18,790	☆	
EFスクレージョイント オネジソケット コア内蔵バルブ対応 	50	FOSC50	6	15,940	☆	
	65	FOSC65	5	22,970	☆	
	75	FOSC75	2	48,880	☆	

※ 受注生産品です。

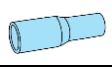
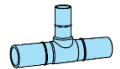
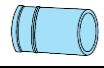
6) エスロハイパー-AW高圧消火 バイブ
(消火設備配管用高性能ポリエチレン管)

品名	サイズ	品番	梱包数	価格(円/本)	改定	備考
プレーンエンド直管 長さ:5,000mm 	100	SP1H5	1	43,200		
	125	SP1Q5	1	64,980		
	150	SP1F5	1	74,250		

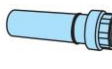
7) エスロハイパー-AW高圧消火 継手
(消火設備配管用高性能ポリエチレン管用継手)

品名	サイズ	品番	梱包数	価格(円/個)	改定	備考
EFソケット 	100	SES1H	12	18,790		
	125	SES1Q	3	27,100		
	150	SES1F	4	32,670		
EF90°エルボ 	100	SEL1H	4	36,300		
EF45°エルボ 	100	SE4L1H	4	35,330		
EFチーズ 	100 × 50	SET1H3	4	26,820		
	100	SET1H	4	50,170		
90°ショートバンド 	125	SS9L1Q	2	46,220		
	150	SS9L1F	2	70,540		
レデューサ 	125 × 100	SSRS1Q1	4	21,540		
	150 × 100	SSRS1F2	2	29,560		
	150 × 125	SSRS1F1	2	35,330		
SPチーズ 	125 × 125	SSPT1Q	1	71,390		
	150 × 100	SSPT1F2	1	125,200		
	150 × 150	SSPT1F	1	142,270		
SPキャップ 	100	SSC1H	2	23,570		
	150	SSC1F	1	39,740		
フランジ短管 G形 JIS20K 材質:SUS 	100	SFS1HO	1	52,940		
	125	SFS1QJ	1	71,630		
	150	SFS1FJ	1	73,380		
フランジ短管 G形 JIS20K 材質:SS400 	100	SMS1HO	1	47,670		
	150	SMS1FJ	1	66,070		
フランジ短管 F形 JIS20K 材質:SUS 	100	SSF1HF	1	52,940		
	125	SFS1QT	1	71,630		
	150	SFS1FT	1	73,380		
フランジ短管 F形 JIS20K 材質:SS400 	100	SSM1HF	1	47,670		
	150	SMS1FT	1	66,070		
SPスクレージョイント (メネジ) 	100	SSPSC1H	1	121,440	☆	
EFスクレージョイント メネジソケット 	50 × Rc1	SEMS503	6	37,570	☆	





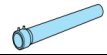

8) エスロハイパー-AW HP パイプ

(給水用耐震型高性能ポリエチレン管[高圧型]) [PWA 005 (PN16) 規格適合品]

品名	サイズ	品番	梱包数	価格(円/本)	改定	備考
プレーンエンド直管 長さ: 5,000mm 	20	TP205	10	2,870		○
	25	TP255	10	3,630		○
	30	TP305	10	5,030		○
	40	TP405	5	7,160		○
	50	TP505	5	9,980		○
	65	TP655	2	16,020	新	
	75	TP755	2	21,560		
	100	TP1H5	2	32,310		
	125	TP1Q5	1	48,590	新	
	150	TP1F5	1	55,510		
	200	TP2H5	1	92,420	新	
EF受口付直管 有効長: 5,000mm 	75	TKP755	2	30,770		
	100	TKP1H5	2	47,730		
	150	TKP1F5	1	83,580		











○ ストライプライン付きです。
プレーンエンド直管の呼び径65~200は2026年下期以降に
順次ストライプライン付きに切り替え予定です。
品番は従来品と同じです。

9) エスロハイパー-AW HP 継手 (給水用耐震型高性能ポリエチレン管用継手[高圧型])
[PWA 006 (PN16) 規格適合品]

品名	サイズ	品番	梱包数	価格(円/個)	改定	備考
EFソケット 	20	TES20	160	2,210		
	25	TES25	140	2,610		
	30	TES30	80	2,680		
	40	TES40	64	3,310		
	50	TES50	40	3,560		
	75	TES75	24	7,290		
	100	TES1H	12	12,210		
EFレデューサ 	25×20	TRS251	144	2,320		
	30×25	TRS301	96	2,830		
	40×30	TRS401	48	4,960		
	50×30	TRS502	40	5,470		
	50×40	TRS501	32	7,450		
レデューサ 	30×20	TSRS302	128	1,890		
	40×20	TSRS403	84	2,050		
	40×25	TSRS402	84	2,130		
	50×20	TSRS504	60	2,520		
	50×25	TSRS503	60	2,520		
	75×50	TSRS752	20	10,380		
	100×75	TSRS1H1	8	12,500		
	150×100	TSRS1F2	2	19,210		
EF片受レデューサ 	75×50	TKRS752	2	24,540		
	100×75	TKRS1H1	2	29,670		
	150×100	TKRS1F2	2	47,670		
EF90°エルボ 	20	TEL20	80	2,740		
	25×20	TEL251	80	2,930		
	25	TEL25	80	2,930		
	30	TEL30	60	2,980		
	40	TEL40	40	5,290		
	50	TEL50	30	6,190		
	75	TEL75	8	12,640		
EF45°エルボ 	20	TE4L20	108	2,680		
	25	TE4L25	84	2,840		
	30	TE4L30	40	3,080		
	40	TE4L40	32	5,040		
	50	TE4L50	36	5,980		
	75	TE4L75	12	12,280		
	100	TE4L1H	4	22,970		



9) エスロハイパー-AW HP 継手 (給水用耐震型高性能ポリエチレン管用継手[高圧型])

[PWA 006 (PN16) 規格適合品]





品名	サイズ	品番	梱包数	価格(円/個)	改定	備考	
EFチーズ 	20×20	TET20	64	6,610			
	25×20	TET251	40	6,780			
	25×25	TET25	64	7,120			
	30×20	TET302	32	6,940			
	30×25	TET301	32	7,120			
	30×30	TET30	40	7,360			
	40×20	TET403	28	9,100			
	40×25	TET402	28	9,250			
	40×40	TET40	20	9,910			
	50×20	TET504	20	10,240			
	50×25	TET503	20	10,430			
	50×40	TET501	20	11,300			
	50×50	TET50	20	11,850			
	75×20	TET756	8	12,220			
	75×25	TET755	8	12,400			
	75×40	TET753	7	12,630			
	75×50	TET752	7	12,760			
	75×75	TET75	6	13,050			
	100×50	TET1H3	4	17,420			
	100×75	TET1H1	4	31,420			
100×100	TET1H	4	32,620				
EF片受チーズ 	150×75	TKT1F3	1	112,210			
	150×100	TKT1F2	1	112,880			
	150×150	TKT1F	1	115,840			
45°ショートバンド 	75	T4L75	16	12,430			
	100	T4L1H	2	20,110			
	150	T4L1F	2	35,510			
90°ショートバンド 	75	TS9L75	12	13,260			
	150	TS9L1F	2	45,860			
フランジ短管 G形 JIS20K 	50	TFS50O	1	24,560			
	75	TFS75O	1	35,940			
	100	TFS1HO	1	46,100			
フランジ短管 F形 JIS20K 	50	TFS50F	1	24,560			
	75	TSF75F	1	35,940			
	100	TSF1HF	1	46,100			
フランジ短管 150 TSF1FF	150	TSF1FF	1	79,860			
	EFフランジ短管 G形 JIS20K 	75	TKF75O	1	45,010		
		100	TKF1HO	1	60,140		
150		TKF1FO	1	103,580			
EFフランジ短管 F形 JIS20K 	75	TKF75F	1	45,010			
	100	TKF1HF	1	60,140			
	150	TKF1FF	1	103,580			
EFスクリージョイント オネジソケット コア内蔵バルブ対応 	20	TEOS20	35	7,710	☆		
	25	TOSC25	16	9,350	☆		
	30	TOSC30	15	13,570	☆		
	40	TOSC40	12	17,730	☆		
	50	TOSC50	6	20,720	☆		
EFスクリージョイント メネジソケット 	20	TEMS20	35	8,270	☆		
	25	TEMS25	16	10,910	☆		
	30	TEMS30	15	16,960	☆		
	40	TEMS40	12	20,940	☆		
	50	TEMS50	6	22,780	☆		

空調配管用高性能ポリエチレン管・継手





1)クウチョウハイパーCH パイプ (空調配管用高性能ポリエチレン管)

品名	サイズ	品番	梱包数	価格(円/本)	改定	備考
プレーンエンド直管 (パープル) 長さ: 5,000mm 	50	CH505P	5	10,770		
	65	CH655P	2	17,660		
	75	CH755P	2	22,630		
	100	CH1H5P	2	37,030		
	125	CH1Q5P	1	57,510		
	150	CH1F5P	1	71,870		
	200	CH2H5P	1	119,060		
プレーンエンド直管 (イエロー) 長さ: 5,000mm 	50	CH505Y	5	10,770	※	
	65	CH655Y	2	17,660	※	
	75	CH755Y	2	22,630	※	
	100	CH1H5Y	2	37,030	※	
	125	CH1Q5Y	1	57,510	※	
	150	CH1F5Y	1	71,870	※	
	200	CH2H5Y	1	119,060	※	
EF受口付直管 (パープル) 有効長: 5,000mm 	75	CKS755P	2	31,820		
	100	CKS1H5P	2	50,460		
	150	CKS1F5P	1	92,570		
	200	CKS2H5P	1	162,020		
EF受口付直管 (イエロー) 有効長: 5,000mm 	75	CKS755Y	2	31,820	※	
	100	CKS1H5Y	2	50,460	※	
	150	CKS1F5Y	1	92,570	※	
	200	CKS2H5Y	1	162,020	※	





2)クウチョウハイパーCH 継手 (空調配管用高性能ポリエチレン管用継手)



品名	サイズ	品番	梱包数	価格(円/個)	改定	備考
EFソケット 	50	CES50	40	3,010		
	65	CES65	20	4,710		
	75	CES75	24	5,890		
	100	CES1H	12	9,860		
	125	CES1Q	3	14,230		
	150	CES1F	4	17,060		
	200	CES2HI	1	39,080		
	EF90°エルボ 	50	CEL50	30	5,010	
65		CEL65	15	8,350		
75		CEL75	8	10,710		
100		CEL1H	4	19,000		
EF45°エルボ 	50	CE4L50	36	4,910		
	65	CE4L65	18	7,890		
	75	CE4L75	12	9,710		
	100	CE4L1H	4	17,160		
EFチーズ 	50×20	CET504	20	8,270		
	50×25	CET503	20	8,420		
	50×50	CET50	20	9,580		
	65×20	CET655	16	9,050		
	65×25	CET654	16	9,220		
	65×50	CET651	10	9,960		
	65×65	CET65	10	10,040		
	75×20	CET756	8	9,850		
	75×25	CET755	8	10,010		
	75×50	CET752	7	10,320		
	75×75	CET75	6	10,530		
	100×50	CET1H3	4	14,070		
	100×75	CET1H1	4	25,360		
	100×100	CET1H	4	26,330		

※ 受注生産品です。

品名	サイズ	品番	梱包数	価格(円/個)	改定	備考
レデューサ 	50×20	CSRS504	60	2,040		
	50×25	CSRS503	60	2,040		
	65×50	CSRS651	25	8,700		
	75×50	CSRS752	20	9,150		
	75×65	CSRS751	16	10,290		
	100×75	CSRS1H1	8	10,920		
	125×100	CSRS1Q1	4	13,920		
	150×100	CSRS1F2	2	16,700		
	150×125	CSRS1F1	2	19,440		
	200×150	CSRS2H1	2	25,650		
EF片受チーズ 	150×50	CKT1F5	1	90,510		
	150×65	CKT1F4	1	90,510		
	150×75	CKT1F3	1	90,510		
	150×100	CKT1F2	1	91,110		
	150×150	CKT1F	1	93,530		
	200×50	CKT2H6	1	137,210		
	200×65	CKT2H5	1	137,210		
	200×75	CKT2H4	1	137,210		
	200×100	CKT2H3	1	140,240		
	200×150	CKT2H1	1	145,320		
SPチーズ 	125×50	CSPT1Q4	1	36,060		
	125×65	CSPT1Q3	1	36,060		
	125×100	CSPT1Q1	1	36,060		
	125×125	CSPT1Q	1	37,510		
	150×50	CSPT1F5	1	71,750	※	
	150×65	CSPT1F4	1	71,750	※	
	150×75	CSPT1F3	1	71,750	※	
	150×100	CSPT1F2	1	72,240	※	
	150×150	CSPT1F	1	74,660	※	
	200×50	CSPT2H6	1	94,260	※	
	200×65	CSPT2H5	1	94,260	※	
	200×75	CSPT2H4	1	94,260	※	
	200×100	CSPT2H3	1	97,160	※	
	200×150	CSPT2H1	1	102,370	※	
200×200	CSPT2H	1	106,480	※		
45°ショートバンド 	75	CS4L75	16	10,040		
	100	CS4L1H	2	16,210		
	125	CS4L1Q	2	20,690		
	150	CS4L1F	2	28,680		
	200	CS4L2H	1	50,820		
90°ショートバンド 	75	CS9L75	12	10,650		
	125	CS9L1Q	2	24,320		
	150	CS9L1F	2	37,030		
	200	CS9L2H	1	62,800		



2)クウチョウハイパーCH 継手 (空調配管用高性能ポリエチレン管用継手)

品名	サイズ	品番	梱包数	価格(円/個)	改定	備考
フランジ短管 F形JIS10K 材質:SS400 	50	CMS50R	1	15,360		
	65	CMS65R	1	16,670		
	75	CSM75T	1	17,330		
	100	CSM1HT	1	21,240		
	125	CSM1QT	1	30,820		
	150	CSM1FT	1	34,750		
	200	CSM2HT	1	47,050		
EFキャップ 	50	CEC50	48	5,680		
	75	CEC75	21	7,410		
SPキャップ 	100	CSC1H	2	12,340		
	150	CSC1F	1	20,810		
EFフランジ短管 F形JIS10K 材質:SS400 	75	CKM75T	1	32,540		
	100	CKM1HT	1	43,680		
	150	CKM1FT	1	56,440		
	200	CKM2HT	1	79,090		

品名	サイズ	品番	梱包数	価格(円/個)	改定	備考
EFスクリュージョイント オネジソケット 	20	CEOS20	35	6,200	☆	
	25	CEOSC25	16	7,540	☆	
	50	CEOSC50	6	16,730	☆	
	65	COSC65	5	24,210	☆	
EFスクリュージョイント メネジソケット 	20	CEMS20	35	6,680	☆	
	25	CEMS25	16	8,820	☆	
	50	CEMS50	6	18,390	☆	
	50×Rc3/4	CEMS504	6	18,390	☆	
	50×Rc1	CEMS503	6	18,390	☆	
	50×Rc11/4	CEMS502	6	18,390	☆	
	50×Rc11/2	CEMS501	6	18,390	☆	

品名	サイズ	品番	梱包数	価格(円/本)	改定	備考
クウチョウハイパーCH専用 やりとり短管 長さ:1,000mm 	50	CP501	1	14,160		
	65	CP651	1	15,000		
	75	CP751	1	15,970		
	100	CP1H1	1	18,510		
	125	CP1Q1	1	21,180		
	150	CP1F1	1	24,560		
	200	CP2H1	1	33,030		

■完全固定用部材

品名	サイズ	品番	梱包数	価格(円/個)	改定	備考
専用床バンド(ゴム付) 	50	CHUB50	2	15,400		
	65	CHUB65	2	16,500		
	75	CHUB75	2	21,100		
	100	CHUB1H	2	28,990		
	125	CHUB1Q	2	39,380		
	150	CHUB1F	1	47,140		
	200	CHUB2H	1	58,110		
スパーサー 	50	CHSP50	4	4,870		
	65	CHSP65	4	5,500		
	75	CHSP75	4	5,890		
	100	CHSP1H	4	7,040		
	125	CHSP1Q	4	9,350		
	150	CHSP1F	2	10,070		
	200	CHSP2H	2	13,510		

冷温水管 空調配管用高性能ポリエチレン管

クウチョウハイパーCH

空調設備工事を支える管材に
EF45°エルボの
呼び径75・100を
新たに追加!

積水化学がご提案する
オールプラスチックの一体化ライン!

- 50~200Aをラインアップ
- 冷温水管に水道管路で豊富な実績があるポリエチレン配管で耐久性・耐食性アップ
- 2色展開で誤接続防止に貢献!!

品揃え拡充!!

EF45°エルボ 呼び径75・100



75A 100A

施工性UP

納まり改善

コスト削減

地中熱利用システム

1) エスロート地中熱〈ボアホール型・基礎杭型〉

品名	サイズ	品番	梱包数	価格(円/巻)	改定	備考
ボアホール型用・ 基礎杭型用 地中熱交換器						
管長さ:60m	25	AW2560	1	135,100		○
管長さ:110m	25	AW251H	1	203,640		○
管長さ:105m	30	AW301H	1	206,310		○

○ ストライプライン付きです。

品名	サイズ	品番	梱包数	価格(円/個)	改定	備考
EFソケット	25	KES25WK	120	2,150		
	30	KES30WK	72	2,230		
	40	KES40WK	48	2,760		
	50	KES50K	32	2,980		
	65	KES65	20	4,480		
	75	HES75N	24	5,610		
	100	HES1HN	12	9,390		
EF90°エルボ	25	KEL25WK	48	2,390		
	30	KEL30WK	48	2,460		
	40	KEL40WK	32	4,290		
	50	KEL50MK	24	5,010		
	65	KEL65	15	7,620		
	75	HEL75	8	9,720		
	100	HEL1H	4	18,150		
EF45°エルボ	25	KE4L25K	72	2,330		
	30	KE4L30K	32	2,530		
	40	KE4L40K	24	4,090		
	50	KE4L50K	24	4,840		
	65	KE4L65	18	7,500		
	75	HE4L75N	12	9,440		
	100	HE4L1H	4	17,670		
EFチーズ	25×25	KET25WK	64	5,620		
	30×25	KET301K	32	5,640		
	50×25	KET503K	20	8,260		
	50×50	KET50WK	16	9,360		
	65×25	KET654	16	8,780		
	65×50	KET651	10	9,320		
	65×65	KET65	10	9,440		
	75×25	HET755	8	9,540		
	75×40	HET753	7	9,710		
	75×50	HET752N	7	9,820		
	75×75	HET75N	6	10,030		
	100×50	HET1H3N	4	13,410		
	100×75	HET1H1N	4	24,170		
	100×100	HET1HN	4	25,090		

品名	サイズ	品番	梱包数	価格(円/個)	改定	備考
EFスクリュージョイント オネジソケット	25	KOSC25K	16	7,280	☆	
	30	KOSC30K	12	10,530	☆	
コア内蔵バルブ対応						
EFスクリュージョイント メネジソケット	25	KEMS25K	16	8,480	☆	
	30	KEMS30K	12	13,160	☆	
EFスクリュージョイント ユニオンソケット	25	KEUS25K	16	8,190	☆	
	30	KEUS30K	12	14,820	☆	
T形サドル	50×25	HTSD503	32	4,280		
	50×30	HTSD502	32	4,580		
	75×25	HTSD755	24	4,360		
	75×30	HTSD754	24	4,660		
	100×30	HTSD1H5	12	5,200		
媒介継手90° ユニオンエルボ	25	AB9UL25	24	8,120	☆	
媒介継手60° ユニオンエルボ	25	AB6UL25	24	8,310	☆	
媒介継手 ストレートユニオン	25	ABSTU25	24	6,960	☆	
媒介継手ソケット	25	ABS25	60	6,270	☆	

エスロート地中熱

外気と地中との温度差を利用し、少ない電気エネルギーで建物空調や道路融雪が行えます。

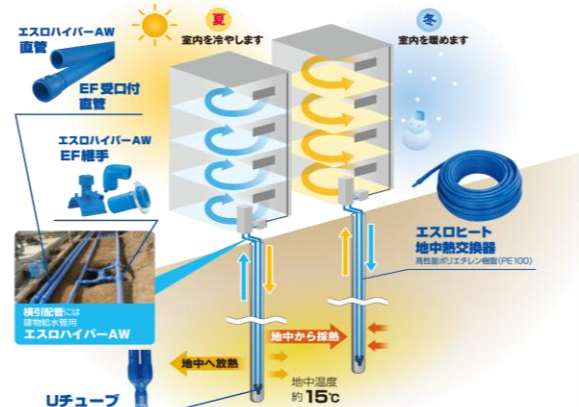

※ エスロート地中熱(水平型)については、弊社営業所へお問い合わせください

1) フィブロック (熱膨張耐火材 区画貫通テープ/区画貫通用シート)

品名	サイズ	品番	梱包数	価格(円/巻・セット)	改定	備考
エスロハイパー-AW用 (20~75用) 	1.5m/巻	FIBAW	6	12,100		
エスロハイパー-AW用 (100以下用) 	0.42m/巻	FIBAW1H	6	21,780		
エスロハイパー-AW用 (200以下用) 	1.0m/セット	FIBCH2H	10	23,600		
さや管用 	2.0m/巻	TBBZ001	12	31,600		
保温材付 スーパーエスロメタックス用 	1.3m/巻	FIB-FC	6	16,010		
塩ビ管用 (壁用) 	1.5m/巻	TBCZ002	6	17,540		
塩ビ管用 (床用) 	1.5m/巻	TBCZ001	6	26,310		
冷媒管用 	1.2m/巻	TCEZ001	6	16,010		
冷媒管用パテレスキット 	75	RBK-075	10	5,440		
	100	RBK-100	10	6,970		
	125	RBK-125	10	10,300		
	150	RBK-150	10	12,390		

施工可能箇所数(目安)

エスロハイパー-AW用	呼び径	φ20	φ25	φ30	φ40
	箇所数	15	12	10	9
	呼び径	φ50	φ65	φ75	φ100
	箇所数	7	6	5	1
	呼び径	φ125	φ150	φ200	
	箇所数	2	2	2	

さや管用	呼び径	φ22	φ25	φ28	φ30
	箇所数	20	18	17	16
	呼び径	φ36			
	箇所数	14			

さや管用 (コルゲートウォームの場合)	呼び径	φ10	φ13	φ16	φ20
	箇所数	20	18	16	14

さや管用 (エスロベックスCVの場合)	呼び径	φ10	φ13	φ16	φ20
	箇所数	26	26	22	18

保温材付スーパーエスロメタックス用	呼び径	φ10	φ13	φ16	φ20
	保温材10mm 箇所数	10	10	9	8
	保温材20mm 箇所数	7	6	6	5
	保温材25mm 箇所数	—	5	5	5
	保温材30mm 箇所数	—	—	—	4
	呼び径	φ25	φ32	φ40	φ50
	保温材10mm 箇所数	7	6	5	4
	保温材20mm 箇所数	5	4	4	3
	保温材25mm 箇所数	4	4	3	3
	保温材30mm 箇所数	4	3	3	3

塩ビ管用	呼び径	φ13	φ16	φ20	φ25
	箇所数	22	18	16	13
	呼び径	φ30	φ40	φ50	φ65
	箇所数	11	9	7	6
	呼び径	φ75	φ100	φ125	φ150
	箇所数	5	4	3	2

塩ビ管用 (ACドレンパイプの場合)	呼び径	φ20	φ25	φ30	φ40
	箇所数	13	11	9	7
	呼び径	φ50	φ65		
	箇所数	6	5		

フィブロック® 検索システム

Search system

品番・品名、
認定番号・評定番号から、
施工条件検索まで。

見つける、見つかる
フィブロック検索システム



携帯からは
こちら!



<https://www.fiblock.com/>

1) エスロベックス (架橋ポリエチレン管PN15)[JIS K 6769]

品名	サイズ	品番	梱包数	価格(円/巻)	改定	備考	
エスロベックス (100m/巻)	10	PEX10J	1	40,740			
	13	PEX13J	1	45,440			
	16	PEX16J	1	76,140			
	20	PEX20J	1	88,840			
エスロベックスCV (50m/巻)	10	PH1003B	1	34,320	※1		
	10	PH1003Y	1	34,320	※1		
	13	PH1303B	1	36,650	※1		
	13	PH1303Y	1	36,650	※1		
	16	PH1603B	1	52,020	※1		
	16	PH1603Y	1	52,020	※1		
	20	PH2003B	1	58,380	※1		
20	PH2003Y	1	58,380	※1			
ラクのびベックスCV (45m/巻)	13	TM13B45	1	36,650	※1		
	13	TM13Y45	1	36,650	※1		
	16	TM16B45	1	52,020	※1		
	16	TM16Y45	1	52,020	※1		
	20	TM20B45	1	58,380	※1		
	20	TM20Y45	1	58,380	※1		
ラクのびベックス コルゲートウォーム (45m/巻) (22m/巻)	10	CW10B45	1	26,690	※2		
	10	CW10P45	1	26,690	※2		
	13	CW13B45	1	29,900	※2		
	13	CW13P45	1	29,900	※2		
	16	CW16B22	1	21,430	※2		
	16	CW16P22	1	21,430	※2		
	20	CW20B22	1	24,690	※2		
	20	CW20P22	1	24,690	※2		
保温付エスロベックス 5mm保温 (50m/巻)	10	PX1005B	1	40,700	※1		
	10	PX1005Y	1	40,700	※1		
	13	PX1305B	1	43,500	※1		
	13	PX1305Y	1	43,500	※1		
	16	PX1605B	1	61,800	※1		
	16	PX1605Y	1	61,800	※1		
	20	PX2005B	1	69,300	※1		
20	PX2005Y	1	69,300	※1			
保温付エスロベックス 10mm保温 (50m/巻)	10	PX1010B	1	56,380	※1		
	10	PX1010Y	1	56,380	※1		
	13	PX1310B	1	64,430	※1		
	13	PX1310Y	1	64,430	※1		
	16	PX1610B	1	88,590	※1		
	16	PX1610Y	1	88,590	※1		
	20	PX2010B	1	103,900	※1		
20	PX2010Y	1	103,900	※1			
保温付ラクのびベックス 10mm保温 (45m/巻)	13	TH13B45	1	64,430	※1		
	13	TH13Y45	1	64,430	※1		
	16	TH16B45	1	88,590	※1		
	16	TH16Y45	1	88,590	※1		
	20	TH20B45	1	103,900	※1		
	20	TH20Y45	1	103,900	※1		

品名	サイズ	品番	梱包数	価格(円/本)	改定	備考
エスロベックスCV 直管タイプ(3m/本)	13	PH13B03	30	2,640	※1	
	13	PH13Y03	30	2,640	※1	
	16	PH16B03	20	3,760	※1	
	16	PH16Y03	20	3,760	※1	
	20	PH20B03	14	4,240	※1	
	20	PH20Y03	14	4,240	※1	
保温付エスロベックス 直管タイプ(3m/本)	13	PX135B3	14	3,400	※1	
	13	PX135Y3	14	3,400	※1	
	16	PX165B3	10	4,840	※1	
	16	PX165Y3	10	4,840	※1	
	20	PX205B3	8	5,430	※1	
	20	PX205Y3	8	5,430	※1	

※1. エスロベックスCVと保温付エスロベックス、ラクのびベックスCVには、ブルーとオレンジの2種類があります(品番末尾 B:ブルー Y:オレンジ)
 ※2. ラクのびベックスコルゲートウォームには、ブルーとピンクの2種類があります(品番5桁目 B:ブルー P:ピンク)

品名	サイズ	品番	梱包数	価格(円/個)	改定	備考
パイプ保温材補修テープ	ブルー	30mm幅	HDHC30B	120	1,840	
		30mm幅	HDHC30Y	120	1,890	
	オレンジ	50mm幅	HDHC50B	80	3,010	
		50mm幅	HDHC50Y	80	3,160	

2) エスロカチットS (架橋ポリエチレン管用ワンタッチ継手)

品名	サイズ	品番	梱包数	価格(円/個)	改定	備考
オスねじアダプター	10×R1/2	SMOA10	104(26×4箱)	2,720	☆	
	13×R1/2	SMOA13	80(20×4箱)	3,130	☆	
	13×R3/4	SMOA132	80(20×4箱)	3,480	☆	
	16×R1/2	SMOA16	60(15×4箱)	3,910	☆	
	16×R3/4	SMOA162	60(15×4箱)	4,160	☆	
	20×R3/4	SMOA20	48(12×4箱)	6,470	☆	
	13×G1/2	SMOA13G	80(20×4箱)	3,160	☆	
	16×G3/4	SMO162G	60(15×4箱)	4,130	☆	
ユニオン(袋ナット)	10×G1/2	SPF10	96(24×4箱)	3,020	☆	
	13×G1/2	SPF13	80(20×4箱)	3,210	☆	
	13×G3/4	SPF132	64(16×4箱)	3,830	☆	
	16×G1/2	SPF16	64(16×4箱)	4,190	☆	
	16×G3/4	SPF162	60(15×4箱)	4,340	☆	
20×G3/4	SPF20	40(10×4箱)	6,040	☆		
ユニオンエルボ	13×G1/2	SMUL13	80(20×4箱)	4,930	☆	
メスねじアダプター	10×Rc1/2	SMMA10	96(24×4箱)	2,980	☆	
	13×Rc1/2	SMMA13	80(20×4箱)	3,300	☆	
	16×Rc1/2	SMMA16	60(15×4箱)	4,300	☆	
	16×Rc3/4	SMMA162	60(15×4箱)	4,600	☆	
	20×Rc3/4	SMMA20	48(12×4箱)	6,120	☆	
Eチーズ(樹脂製)	13	SPT13	40(10×4箱)	2,930		
	16	SPT16	24(6×4箱)	3,940		
	16×13	SPT161	32(8×4箱)	3,930		
	16×13×13	SPT161T	32(8×4箱)	3,660		
	20×13	SPT20	24(6×4箱)	5,380		
20×16	SPT201	24(6×4箱)	5,390			
Eソケット(樹脂製)	13	SPS13	64(16×4箱)	1,960		
	16	SPS16	48(12×4箱)	2,780		
	16×13	SPS161	48(12×4箱)	2,530		
	20×16	SPS201	40(10×4箱)	3,850		
Eエルボ(樹脂製)	13	SPL13	60(15×4箱)	2,070		
	16	SPL16	40(10×4箱)	2,960		
	20	SPL20	32(8×4箱)	4,170		
チーズ(砲金製)	13	SMT13	40(10×4箱)	7,310	☆	
	16	SMT16	24(6×4箱)	8,960	☆	
	20	SMT20	20(5×4箱)	13,180	☆	
	13×10	SMT131	48(12×4箱)	7,260	☆	
	13×10×10	SMT131T	48(12×4箱)	7,240	☆	
	16×13	SMT161	32(8×4箱)	8,930	☆	
	16×13×13	SMT161T	32(8×4箱)	8,890	☆	
	20×13	SMT20	24(6×4箱)	13,100	☆	
	20×13×13	SMT202T	32(8×4箱)	13,070	☆	
	20×16	SMT201	24(6×4箱)	13,150	☆	
ソケット(砲金製)	10	SMS10	80(20×4箱)	4,070	☆	
	13	SMS13	64(16×4箱)	4,520	☆	
	16	SMS16	48(12×4箱)	6,430	☆	
	20	SMS20	32(8×4箱)	8,740	☆	
	13×10	SMS131	80(20×4箱)	4,480	☆	
	16×13	SMS161	48(12×4箱)	6,370	☆	
	20×13	SMS20	48(12×4箱)	8,660	☆	
	20×16	SMS201	40(10×4箱)	8,700	☆	

2)エスロカチットS (架橋ポリエチレン管用ワンタッチ継手)

品名	サイズ	品番	梱包数	価格(円/個)	改定	備考
	13	SML13	60(15×4箱)	5,480	☆	
	16	SML16	40(10×4箱)	6,800	☆	
	20	SML20	32(8×4箱)	10,980	☆	
	20×13	SML202	40(10×4箱)	10,920	☆	
	20×16	SML201	40(10×4箱)	10,960	☆	
	10×Rp1/2	SMWL10	72(18×4箱)	4,190	☆	
	13×Rp1/2	SMWL13	60(15×4箱)	4,430	☆	
	10×Rp1/2	SMWL10Z	48(12×4箱)	4,600	☆	
	13×Rp1/2	SMWL13Z	40(10×4箱)	5,060	☆	
	16×Rp3/4	SMW162Z	32(8×4箱)	5,840	☆	
	10×Rp1/2	SMWL10D	48(12×4箱)	4,600	☆	
	13×Rp1/2	SMWL13D	40(10×4箱)	5,060	☆	
	13×Rp1/2	SMW13DL	40(10×4箱)	6,200	☆	
	10×Rp1/2	SMWL10W	48(12×4箱)	5,640	☆	
	13×Rp1/2	SMWL13W	40(10×4箱)	6,070	☆	
	16×Rp1/2	SMWL16W	32(8×4箱)	7,000	☆	
	20×Rp1/2	SMWL20W	24(6×4箱)	8,690	☆	
	10×Rp1/2	SPWL10W	48(12×4箱)	2,980	☆	
	13×Rp1/2	SPWL13W	40(10×4箱)	3,140	☆	
	16×Rp1/2	SPWL16W	32(8×4箱)	3,880	☆	
	20×Rp1/2	SPWL20W	24(6×4箱)	4,290	☆	
	10×R1/2	SMVA10	60(15×4箱)	6,890	☆	
	13×R1/2	SMVA13	60(15×4箱)	7,140	☆	
	16×R1/2	SMVA16	48(12×4箱)	7,940	☆	
	13×G1/2	SMTS13	24(6×4箱)	10,340	☆	
	13×G1/2	SMTS13V	60(15×4箱)	9,070	☆	
	13×G1/2	SMVC13	28(7×4箱)	10,740	☆	
	13×G3/4	SMVC132	28(7×4箱)	11,750	☆	
	16×G1/2	SMVC16	28(7×4箱)	13,160	☆	
	16×G3/4	SMVC162	28(7×4箱)	13,430	☆	
	13×Rc1/2	SMYS13S	40(10×4箱)	4,930	☆	
	13×Rc1/2	SMYS13M	32(8×4箱)	7,040	☆	
	13×Rc1/2	SMYS13L	24(6×4箱)	8,740	☆	

品名	サイズ	品番	梱包数	価格(円/個)	改定	備考
	13×Rc1/2	SPYS13S	40(10×4箱)	3,450	新	
	13×Rc1/2	SMYS134	32(8×4箱)	6,370	☆	
	13×Rc1/2	SMY134L	32(8×4箱)	7,430	☆	
	13×Rc1/2	SMZS13	48(12×4箱)	4,790	☆	
	13×Rc1/2	SMZSL13	32(8×4箱)	6,170	☆	
	10×R3/4	SMOL10	72(18×4箱)	4,340	☆	
	13×R3/4	SMOL13	60(15×4箱)	4,340	☆	
	16×R3/4	SMOL16	40(10×4箱)	5,330	☆	
	20×R3/4	SMOL20	40(10×4箱)	7,690	☆	
	10×Rc3/4	SMML10	56(14×4箱)	4,340	☆	
	13×Rc1/2	SMML131	48(12×4箱)	5,420	☆	
	13×Rc3/4	SMML13	48(12×4箱)	5,420	☆	
	20×Rc3/4	SMML20	32(8×4箱)	7,960	☆	
	13×R1/2	SMB13	40(10×4箱)	6,550	☆	
	16×R1/2	SMB16	32(8×4箱)	7,240	☆	
	16×R3/4	SMB162	32(8×4箱)	7,240	☆	
	13×G1/2	SMML13G	40(10×4箱)	6,550	☆	
	16×G1/2	SMB16G	32(8×4箱)	7,240	☆	
	16×G3/4	SMB162G	32(8×4箱)	7,240	☆	
	16×R3/4	SMB162Z	20(5×4箱)	11,150	☆	
	10×R1/2	SMOAL10	80(20×4箱)	4,640	☆	
	13×R1/2	SMOAL13	80(20×4箱)	5,230	☆	
	13×Rc1/2	SMMAL13	48(12×4箱)	6,360	☆	
	13	SMPT13	12(4×3箱)	17,980	☆	
	16	SMPT16	12(4×3箱)	19,430	☆	
	16×13	SMPT161	12(4×3箱)	19,430	☆	
	13	SMPB13	12(4×3箱)	20,160	☆	
	16	SMPB16	12(4×3箱)	21,600	☆	
	16×13	SMPB161	12(4×3箱)	21,600	☆	

2) エスロカチットS (架橋ポリエチレン管用ワンタッチ継手)

品名	サイズ	品番	梱包数	価格(円/個)	改定	備考
ユニットバスエルボ 	13×Rp1/2	SMUB13L	40(10×4箱)	7,360	☆	
ユニットバスエルボ (外ねじ・ナット有) 	13×Rp1/2	SMUB13N	32(8×4箱)	9,190	☆	
床出し調整ジョイント 	ストレート	SMYC13S	48(12×4箱)	5,320	☆	
	45°L	SMYC134	40(10×4箱)	6,890	☆	
	90°L	SMYC13L	40(10×4箱)	7,780	☆	
床出し調整ジョイント (ロングタイプ) 	ストレート	SMYL13S	32(8×4箱)	6,580	☆	
	45°L	SMYL134	32(8×4箱)	7,880	☆	
	45°L	SMYL164	32(8×4箱)	8,270	☆	
	90°L	SMYL13L	32(8×4箱)	8,880	☆	
銅管変換アダプター 	13×15A(銅管)	SMDH13	80(20×4箱)	4,900	☆	
	16×20A(銅管)	SMDH162	60(15×4箱)	6,100	☆	
	20×20A(銅管)	SMDH20	48(12×4箱)	6,430	☆	
調整座金 	13用	KTCZ	60(10×6箱)	590		
	16用	KTCZ0	60(10×6箱)	960		
固定座金 		KTKZ	60(10×6箱)	1,190		
継手用保温材 チーズ用 	13用	FHT13	80(10×8箱)	570		
	16用	FHT16	80(10×8箱)	710		
	20用	FHT20	60(10×6箱)	800		
継手用保温材 ソケット用 	10、13用	FHS13	80(10×8箱)	430		
	16用	FHS16	80(10×8箱)	470		
	20用	FHS20	60(10×6箱)	650		
継手用保温材 エルボ用 	13用	FHL13	80(10×8箱)	480		
	16用	FHL16	80(10×8箱)	610		
	20用	FHL20	80(10×8箱)	700		

3) ペックスヘッダー

品名	サイズ	品番	梱包数	価格(円/個)	改定	備考
ペックスヘッダー 両口タイプ 	H3/4-H1/2×1F	PHD1W	50(50×1箱)	1,200		※
	H3/4-H1/2×2F	PHD2W	50(50×1箱)	1,350		※
	H3/4-H1/2×3F	PHD3W	32(32×1箱)	1,650		※
	H3/4-H1/2×4F	PHD4W	28(28×1箱)	1,950		※
	H3/4-H1/2×5F	PHD5W	25(25×1箱)	2,400		※
	H3/4-H1/2×6F	PHD6W	25(25×1箱)	2,750		※
ペックスヘッダー 片口タイプ 	H3/4-H1/2×2F	PHD2S	50(50×1箱)	1,350		※
	H3/4-H1/2×3F	PHD3S	40(40×1箱)	1,650		※
	H3/4-H1/2×4F	PHD4S	28(28×1箱)	1,950		※
	H3/4-H1/2×5F	PHD5S	25(25×1箱)	2,400		※
	H3/4-H1/2×6F	PHD6S	25(25×1箱)	2,750		※
ペックスヘッダー用 保温カバー(腹割り) 	1P	HHPC1	50(50×1箱)	830		
	2P	HHPC2	50(50×1箱)	1,160		
	3P	HHPC3	50(50×1箱)	1,320		
	4P	HHPC4	50(50×1箱)	1,650		
	5P	HHPC5	50(50×1箱)	1,820		
	6P	HHPC6	50(50×1箱)	2,040		
エスロカチットS ペックスヘッダーアダプター 	10×H1/2	SPOAP10	72(18×4箱)	2,110		
	13×H1/2	SPOAP13	64(16×4箱)	2,290		
	13×H3/4	SPOPI32	40(10×4箱)	2,800		新
	16×H1/2	SPOAPI6	56(14×4箱)	2,560		
	16×H3/4	SPOPI62	40(10×4箱)	2,860		
	20×H3/4	SPOAP20	32(8×4箱)	3,200		
エスロカチットS ペックスヘッダーエルボ 	10×H3/4	SPPL10	40(10×4箱)	2,970		
	13×H3/4	SPPL13	32(8×4箱)	3,200		
	16×H3/4	SPPL16	32(8×4箱)	3,600		
	20×H3/4	SPPL20	24(6×4箱)	4,000		
エスロカチットS ペックスヘッダー バルブ付きアダプター 	13×H1/2	SMPVA13	40(10×4箱)	8,200	☆	
	16×H1/2	SMPVA16	40(10×4箱)	10,990	☆	
ペックスヘッダーニップル 	H3/4	PNI20	48(8×6箱)	3,120		
ペックスヘッダープラグ 	H1/2	PHP15	144(24×6箱)	1,350		
	H3/4	PHP20	96(16×6箱)	1,650		
ペックスヘッダー メスねじニップル 	Rc3/4×H3/4	PMN20	48(8×6箱)	4,600	☆	
HIVP変換アダプター 	13×H1/2	HIVPA13	100	86		
	16×H3/4	HIVPA16	70	114		
	20×H3/4	HIVPA20	50	120		

※ Pは口数を示します

■樹脂ヘッダー配管システム

エスロン® ペックスヘッダー

接続「パチッ!」エスロカチットのDNA。

簡単・確実・スピーディー!



■HIVP管用ペックス変換継手

エスロン® HIVP変換アダプター

HIからPEXへの変換がダイレクトに!



4)ヘッダー

(1) 連鎖ヘッダー(50mmピッチ)関連

品名	口数	品番	梱包数	価格(円/個)	改定	備考
連鎖ヘッダー 15A 	2P	NHD13-2	40(10×4箱)	10,610	☆	
	3P	NHD13-3	30(10×3箱)	14,250	☆	
	4P	NHD13-4	15(5×3箱)	18,090	☆	
	5P	NHD13-5	15(5×3箱)	21,640	☆	
	6P	NHD13-6	5(5×1箱)	25,140	☆	
	7P	NHD13-7	5(5×1箱)	28,760	☆	
	8P	NHD13-8	5(5×1箱)	32,400	☆	
	連鎖ヘッダー 20A 	1P	NRHD201	15(5×3箱)	8,640	☆
2P		NRHD202	40(10×4箱)	9,700	☆	
3P		NRHD203	30(10×3箱)	11,960	☆	
4P		NRHD204	15(5×3箱)	16,040	☆	
5P		NRHD205	15(5×3箱)	19,150	☆	
6P		NRHD206	15(5×3箱)	24,090	☆	
7P		NRHD207	5(5×1箱)	26,600	☆	
8P		NRHD208	5(5×1箱)	30,250	☆	
ヘッダー用保温カバー <ワンタッチタイプ> 背割りタイプ ピッチ50mm 	1P	RHC1S	50(50×1箱)	1,310		
	2P	RHC2S	50(50×1箱)	1,380		
	3P	RHC3S	50(50×1箱)	1,710		
	4P	RHC4S	50(50×1箱)	1,970		
	5P	RHC5S	50(50×1箱)	2,080		
	6P	RHC6S	50(50×1箱)	2,710		
	7P	RHC7S	50(50×1箱)	2,980		
	8P	RHC8S	50(50×1箱)	3,190		

(2)ヘッダー共通付属品

品名	サイズ	品番	梱包数	価格(円/個)	改定	備考
ヘッダーニップル 	15	NPXN15	200(20×10箱)	1,700	☆	
	20	NPXN20	200(20×10箱)	2,580	☆	
並列式 クロス式						
ニップル(全ネジタイプ) 	20	NHDNI20	200(20×10箱)	2,350	☆	
並列式 クロス式						
ヘッダーキャップ 	20	NPXCA20	200(20×10箱)	2,230	☆	
ヘッダープラグ 	15	NPXP15	200(20×10箱)	1,480	☆	
	20	NPXP20	200(20×10箱)	1,700	☆	
ヘッダーブッシング 	20×15	NPXB201	200(20×10箱)	2,010	☆	
ヘッダー固定金具(床用) 	床用	BRYUKA	80(10×8箱)	1,890		
	2P固定用	BRY2P	20(20×1箱)	2,430		
ヘッダー固定金具(Uバンド・L金具) 	Lタイプ	BRL	50(50×1箱)	2,380		
	Sタイプ	BRS	50(50×1箱)	2,380		

品名	サイズ	品番	梱包数	価格(円/個)	改定	備考
継手保温カバー 分岐側用 (オスネジアダプター用) 	10	FHC10	50(50×1箱)	360		
	13	FHC13	50(50×1箱)	360		
	16	FHC16	50(50×1箱)	370		
継手保温カバー メイン用 (オスネジアダプター用) 	13	FHC132	50(50×1箱)	400		
	16	FHC162	50(50×1箱)	410		
	20	FHC20	50(50×1箱)	420		
継手保温カバー メイン用 (ヘッダーオスネジエルボ用) 	13	FHC13OL	50(50×1箱)	820		
	16	FHC16OL	50(50×1箱)	880		
	20	FHC20OL	50(50×1箱)	990		
ヘッダー保温カバー用テープ 	30mm幅	HDHC30T	120(6×20箱)	1,230		

(3)その他部材

品名	名称	品番	梱包数	価格 (円/シート)	改定	備考
行先表示シール ※1 	台所	KRHR01N	50	80		
	洗面	KRHR02N	50	80		
	風呂	KRHR03N	50	80		
	シャワー	KRHR04N	50	80		
	洗濯	KRHR05N	50	80		
	トイレ	KRHR06N	50	80		
	食洗器	KRHR07N	50	80		
	給湯器	KRHR08N	50	80		
	散水栓	KRHR09N	50	80		
	給水	KRHR10N	50	80		
	給湯	KRHR11N	50	80		
	2F洗面	KRHR12N	50	80		
	2Fトイレ	KRHR13N	50	80		
	2F散水栓	KRHR14N	50	80		
	無地	KRHR15N	50	80		
	戸建てセット	KRHR16N	2	1,190		※2
	アパートセット	KRHR17N	4	950		※3

※1. 1シート当たりシール10個です。

※2. 戸建てセット・・・(11種15シート)



台所(2シート)・洗面(2シート)・風呂(2シート)・洗濯(1シート)・トイレ(1シート)・給湯器(1シート)・給湯(1シート)・給水(1シート)・2F洗面(1シート)・2Fトイレ(1シート)・無地(2シート)

※3. アパートセット・・・(9種12シート)





台所(2シート)・洗面(2シート)・風呂(2シート)・洗濯(1シート)・トイレ(1シート)・給湯器(1シート)・給湯(1シート)・給水(1シート)・無地(1シート)

5) さや管ヘッダーシステム関連部材

(1) さや管

品名	サイズ	品番	梱包数	価格(円/巻)	改定	備考
エスロフレックス ブルー  長さ: 50m/巻 長さ: 30m/巻	22	FLJ22B	1	18,010		
	25	FLX25B	1	20,040		
	28	FLJ28B	1	19,460		
	30	FLX30B	1	19,900		
	36	FLX36B	1	24,980		
エスロフレックス ピンク  長さ: 50m/巻 長さ: 30m/巻	22	FLJ22P	1	18,010		
	25	FLX25P	1	20,040		
	28	FLJ28P	1	19,460		
	30	FLX30P	1	19,900		
	36	FLX36P	1	24,980		

(2) 水栓ボックス

品名	適合サイズ FLX / PEX	品番	梱包数	価格 (円/個)	改定	備考
水栓ボックス 	22 / 10・13	FBOX22	20	6,070		
	25 / 13	FBOX25	20	6,070		
	28 / 16	GS528NO	20	5,940		
立て型水栓ボックスLF型 	22 / 10・13	FLF22	20	3,770		
	25 / 13	FLF25	20	3,770		
水栓ボックス(薄壁空間用) 	22 / 10	FBOX22U	20	5,780		
洗濯機横水栓ボックス 	22 / 10	FBOX22S	20	6,070		

(3) 水栓ボックス継手



品名	適合サイズ FLX / PEX	品番	梱包数	価格 (円/個)	改定	備考	
カチットスタイブ  S(壁厚: 9~13) S(壁厚: 9~13) M(壁厚: 13~18) M(壁厚: 13~18) L(壁厚: 18~23) L(壁厚: 18~23)	22 / 10	SMK10S	48	4,360	☆		
	22・25 / 13	SMK13S	48	4,690	☆		
	22 / 10	SMK10M	48	4,970	☆		
	22・25 / 13	SMK13M	40	5,140	☆		
	28 / 16	SMBX16M	40	7,220	☆		
	22 / 10	SMK10L	40	5,140	☆		
	22・25 / 13	SMK13L	40	5,300	☆		
	28 / 16	SMBX16L	40	7,610	☆		
	立て型水栓ボックス継手 LF型 カチットスタイブ 	22 / 10	SMKLF10	48	6,610	☆	
		22・25 / 13	SMKLF13	48	7,150	☆	

(4) 水栓ボックス共通付属品

品名	サイズ	品番	梱包数	価格(円/個)	改定	備考
防水リング 		BS4BSR	20	1,050		
防水リング横水栓 		BS4BSRY	20	1,050		
化粧リング 		BS4KSR	20	970		
立て型水栓ボックス用 LFワン座 		WANZA	20	420		
立て型水栓ボックス LF型固定座金 床仕上げ高さ: 85~120 床仕上げ高さ: 100~140		LFZ85	20	1,020		
		LFZ100	20	1,020		

5) さや管ヘッダーシステム関連部材

(5) 立て型水栓ジョイント

品名	適合サイズ	品番	梱包数	価格 (円/個)	改定	備考
	FLX / PEX					
T-1型 床仕上げ高さ:240mm以上 B-1 床仕上げ高さ:140-190mm B-2 床仕上げ高さ:190-240mm B-3  B-1	22 / 10・13	FTS112	50	2,180		
	22 / 10	FTS122	50	2,720		
	22 / 10	FTS132	40	2,930		
T-2型 床仕上げ高さ:240mm以上 B-1 床仕上げ高さ:240mm以上 B-1 床仕上げ高さ:170-220mm B-2 床仕上げ高さ:190-240mm B-3  B-1	22 / 10・13	FTS212	20	2,420		
	25 / 13	FTS215	20	2,420		
	22 / 10	FTS222	20	2,860		
	22 / 10	FTS232	20	3,100		

(6) 立て型水栓ジョイント継手



品名	サイズ	品番	梱包数	価格(円/個)	改定	備考
立て型水栓ジョイント継手 (Rcねじ) カチットSタイプ 	10	SMTK10	72	3,560	☆	
	13	SMTK13	72	4,120	☆	
SK用立て型水栓ジョイント継手 (Rpねじ) カチットSタイプ 	13	SMTK3SK	72	6,620	☆	

(7) 立て型水栓ジョイント共通付属品

品名	サイズ	品番	梱包数	価格(円/個)	改定	備考
固定座金 		SGS110	50	1,050		
調整座金 		SGS111	50	820		
サポートバー 		SGS112	50	1,160		

(8) さや管ヘッダー付属品

品名	サイズ	品番	梱包数	価格	改定	備考
				(円/個・巻)		
さや管コーナーサポート 	FLX18用	ISK1618	10	600		
	FLX22・25用	ISK2225	10	800		
	FLX28・30用	ISK2830	10	1,320		
遮熱管 (50m/巻) 	14	ICU-14	1	12,080		
	16	ICU-16	1	13,360		
	22	ICU-22	1	13,360		
	28	ICU-28	1	14,480		
端末キャップ 	18	ISE-18	50	27		
	22	ISE-22	50	37		
	25	ISE-25	50	37		
	28	ISE-28	50	48		
	30	ISE-30	50	48		
	36	ISE-36	50	95		
さや管両サドル 	18	ISD-18A	400	55		
	22	ISD-22	300	74		
	25	ISD-25	300	74		
	28	ISD-28	200	74		
	30	ISD-30	160	92		
	36	ISD-36	120	111		
さや管連結サドル 	22	ISC-22	300	92		
	25	ISC-25	200	111		
	28	ISC-28	160	111		
	30	ISC-30	160	111		
	36	ISC-36	120	111		

品名	適合サイズ	品番	梱包数	価格	改定	備考
	FLX / PEX			(円/個)		
シールキャップ ブルー 	18 / 10	SP1810B	200	200		
	22 / 10	SP2210B	200	200		
	22 / 13	SP2213B	200	200		
	25 / 13	SP2513B	200	200		
	28 / 16	SP2816B	200	220		
	30 / 16	SP3016B	200	260		
	36 / 20	SP3620B	200	260		
シールキャップ ピンク 	18 / 10	SP1810P	200	200		
	22 / 10	SP2210P	200	200		
	22 / 13	SP2213P	200	200		
	25 / 13	SP2513P	200	200		
	28 / 16	SP2816P	200	220		
	30 / 16	SP3016P	200	260		
	36 / 20	SP3620P	200	260		

6) 水圧テストプラグ













品名	サイズ	品番	梱包数	価格(円/個)	改定	備考
ベックス用水圧テストプラグ エア抜きタイプ 	10	NTP10R	40(10×4箱)	4,580		
	13	NTP13R	40(10×4箱)	4,580		
	16	NTP16R	40(10×4箱)	6,590		
	20	NTP20R	40(10×4箱)	7,460		
ベックス用水圧テストプラグ ねじ接続タイプ 	13	NTP13N	40(10×4箱)	4,380		
	16	NTP16N	40(10×4箱)	6,080		
	20	NTP20N	40(10×4箱)	7,170		

7) エスロンベックスエルボ

品名	サイズ	品番	梱包数	価格(円/個)	改定	備考
ベックスエルボ 	13	PEL13	72	1,540		
	16	PEL16	60	1,780		

8) 配管化粧カバー

(1) シングルタイプ

品名	サイズ	品番	梱包数	価格 (円/本・個)	改定	備考
配管カバーパイプ 	13	JD13N	10	2,750		
	16	JD20N	10	3,630		
給水栓用 エルボカバー 	13	JES-13N	50	610		※
	16(13)	JES-20N	50	630		※
パイプホルダー エスロベックスCV・裸用 	13	JRH13J	200	80		
	16	JRH16J	200	80		
パイプホルダー 保温付エスロベックス (5mm)用 	13	JRH13H	200	80		
	16	JRH16H	200	80		
平面エルボカバー90° 	13	JK13F	50	550		
	16	JK20F	50	620		
立面アウトコーナー90° 	13	JCO13F	50	550		
	16	JCO20F	50	650		
立面インコーナー90° 	13	JCI13F	50	550		
	16	JCI20F	50	650		
平面チーズカバー 	13	JHT13F	50	530		
	16	JHT20F	50	830		
	16(13)	JHT201F	50	830		
ジョイントカバー 	13	JS13	50	470		
	16	JS20	50	500		
ウォールコーナー 	13	JW13F	50	550		
	16	JW20F	50	580		
壁貫通チーズカバー 	13	JWT13	50	500		
	16	JWT20	50	760		
給水用ソケットカバー 	13	JSC13F	50	470		
	16	JSC20F	50	530		
シーリングキャップ 	13	JP13	100	290		
	16	JP20	100	310		

※ エスロカチットS継手専用です

8) 配管化粧カバー
(2) ツインタイプ

品名	サイズ	品番	梱包数	価格 (円/本・個)	改定	備考
配管カバーパイプ 	13・16	TJD20	5	5,870		
平面エルボカバー 90° 	13・16	TJK20	20	970		
立面インコーナー90°ミニ 	13・16	TJCM20	20	750		
立面アウトコーナー90°ミニ 	13・16	TJCOM20	20	750		
平面チーズカバー 	13・16	TJHT20	20	1,300		
壁貫通チーズカバー 	13・16	TJWT20	20	1,200		
ジョイントカバー 	13・16	TJS20	20	680		
ソケットカバー 	13・16	TJSC20	20	730		
シーリングキャップ 	13・16	TJP20	100	460		
シングル 変換アダプター 	13・16	TJAD20	20	530		
ウォールコーナー 	13・16	TJW20	20	810		
混合栓用 ボックスカバー 	13・16	TJMB20	24	2,760		
パイプホルダー エスロベックスCV・裸用 	13	JRH13J	200	80		
	16(13)	JRH16J	200	80		
パイプホルダー 保温付エスロベックス (5mm)用 	13	JRH13H	200	80		
	16	JRH16H	200	80		

(3) 関連製品(エスロカチットS)

品名	サイズ	品番	梱包数	価格(円/個)	改定	備考
ペアチーズ上 	13	SMPT13	12(4×3箱)	17,980	☆	
	16	SMPT16	12(4×3箱)	19,430	☆	
	16×13	SMPT161	12(4×3箱)	19,430	☆	
ペアチーズ下 	13	SMPB13	12(4×3箱)	20,160	☆	
	16	SMPB16	12(4×3箱)	21,600	☆	
	16×13	SMPB161	12(4×3箱)	21,600	☆	

1) スーパーエスロメタックス (金属強化ポリエチレン管)

(1) パイプ(長尺管)

品名	サイズ	品番	梱包数	価格(円/巻)	改定	備考
スーパーエスロメタックス (長尺管)						
長さ: 100m/巻	10	SMX101H	1	53,110		
長さ: 100m/巻	13	SMX131H	1	61,500		
長さ: 50m/巻	16	SMX1650	1	41,240		
長さ: 50m/巻	20	SMX2050	1	64,300		
長さ: 50m/巻	25	SMX2550	1	85,970		

(2) パイプ(直管)

品名	サイズ	品番	梱包数	価格(円/本)	改定	備考
スーパーエスロメタックス (直管)	13	SMX134	40	2,520		
長さ: 4m/本	16	SMX164	30	3,420		
	20	SMX204	20	5,270		
	25	SMX254	15	7,050		
	30	SMX324	10	10,630		
	40	SMX404	6	14,490		
	50	SMX504	4	21,470		

(3) 保温材付パイプ(長尺管: 25m巻)

品名	サイズ	品番	梱包数	価格(円/巻)	改定	備考
保温材付 スーパーエスロメタックス (長尺管)	10	SF1010Q	1	24,480		
保温材厚み: 10mm 長さ: 25m/巻	13	SF1310Q	1	27,130		
	16	SF1610Q	1	36,120		
	20	SF2010Q	1	54,160		
	25	SF2510Q	1	69,050		
保温材付 スーパーエスロメタックス (長尺管)	10	SF1020Q	1	39,560		
保温材厚み: 20mm 長さ: 25m/巻	13	SF1320Q	1	45,250		
	16	SF1620Q	1	48,810		
	20	SF2020Q	1	62,800		
	25	SF2520Q	1	84,300		
保温材付 スーパーエスロメタックス (長尺管)	16	SF1625Q	1	56,790		
保温材厚み: 25mm 長さ: 25m/巻	20	SF2025Q	1	74,890		
	25	SF2525Q	1	98,950		
保温材付 スーパーエスロメタックス (長尺管)	20	SF2030Q	1	81,180		
保温材厚み: 30mm 長さ: 25m/巻	25	SF2530Q	1	112,350		
保温材付 スーパーエスロメタックス (長尺管)	10	UF1010Q	1	30,090		
高耐候10mm 長さ: 25m/巻	13	UF1310Q	1	33,360		
保温材付 スーパーエスロメタックス (長尺管)	10	UF1020Q	1	48,680		
高耐候20mm 長さ: 25m/巻	13	UF1320Q	1	55,660		

(4) 保温材付パイプ(直管: 4m)

品名	サイズ	品番	梱包数	価格(円/本)	改定	備考
保温材付 スーパーエスロメタックス (直管)	13	SF13104	9	5,780		
保温材厚み: 10mm 長さ: 4m/本	16	SF16104	9	6,890		
	20	SF20104	9	7,700		
	25	SF25104	9	9,270		
	32	SF32104	9	13,960		
	40	SF40104	6	17,690		
	50	SF50104	4	26,220		
保温材付 スーパーエスロメタックス (直管)	13	SF13204	9	8,260		
保温材厚み: 20mm 長さ: 4m/本	16	SF16204	9	9,370		
	20	SF20204	9	10,620		
	25	SF25204	9	12,650		
	32	SF32204	9	16,140		
	40	SF40204	4	19,750		
	50	SF50204	4	27,780		
保温材付 スーパーエスロメタックス (直管)	13	SF13254	9	8,930		
保温材厚み: 25mm 長さ: 4m/本	16	SF16254	9	10,260		
	20	SF20254	9	12,640		
	25	SF25254	6	14,910		
	32	SF32254	4	17,670		
	40	SF40254	4	21,350		
	50	SF50254	4	30,730		
保温材付 スーパーエスロメタックス (直管)	20	SF20304	4	13,990		
保温材厚み: 30mm 長さ: 4m/本	25	SF25304	4	16,260		
	32	SF32304	4	20,520		
	40	SF40304	4	25,170		
	50	SF50304	4	33,660		

エスロン スーパーエスロメタックス

新素材・新継手で施工性がアップ。
給水・給湯から空調配管まで幅広くカバー。

- 高温・高圧領域で使用でき、衛生的な管材です。
- 柔軟で自在な曲げ配管。さらに曲げ形状を保持。
- 軽量で取り扱いが容易です。

適用範囲



最高許容水圧	1.5MPa (0~60°C) 1.0MPa (61~85°C) 0.8MPa (86~95°C)
最高許容温度	95°C
曲げ半径	R=4D以上(裸管の場合)
呼び径	10~50 (給水・給湯用) 13~50 (空調用)

※最高許容水圧とは水撃値を含んだ値です。



〈スーパーエスロメタックスの構造〉

2) エスロンメタキュット (スーパーエスロメタックス用圧縮継手)

品名	サイズ	品番	梱包数	価格(円/個)	改定	備考
 オスネジアダプター	10×R1/2	MKOA10	210	2,090	☆	
	13×R1/2	MKOA13	210	2,090	☆	
	16×R3/4	MKOA162	120	2,830	☆	
	16×R1/2	MKOA16	120	2,350	☆	
	20×R3/4	MKOA20	90	3,130	☆	
	25×R1	MKOA25	72	4,180	☆	
	32×R1 1/4	MKOA32	36	5,980	☆	
	40×R1 1/2	MKOA40	24	8,650	☆	
	50×R2	MKOA50	24	10,280	☆	
 ソケット	10	MKS10	210	3,100	☆	
	13	MKS13	210	3,230	☆	
	16	MKS16	150	3,680	☆	
	16×13	MKS161	150	3,510	☆	
	20	MKS20	120	4,790	☆	
	20×13	MKS202	120	4,350	☆	
	20×16	MKS201	120	4,350	☆	
	25	MKS25	72	5,800	☆	
	25×20	MKS251	72	6,100	☆	
	32	MKS32	45	7,980	☆	
	32×20	MKS322	45	8,160	☆	
	32×25	MKS321	45	8,160	☆	
	40	MKS40	32	11,800	☆	
	40×25	MKS402	16	12,350	☆	
	40×32	MKS401	32	12,350	☆	
	50	MKS50	24	15,030	☆	
50×32	MKS502	12	16,070	☆		
50×40	MKS501	24	16,070	☆		
 チーズ	13	MKT13	96	5,330	☆	
	16	MKT16	72	5,830	☆	
	16×13	MKT161	96	5,480	☆	
	16×13×13	MKT1633	96	5,480	☆	
	20	MKT20	48	7,280	☆	
	20×13	MKT202	60	7,100	☆	
	20×13×13	MKT2033	24	7,100	☆	
	20×16	MKT201	48	7,100	☆	
	25	MKT25	36	8,800	☆	
	25×16	MKT252	48	8,430	☆	
	25×20	MKT251	48	8,600	☆	
	32	MKT32	24	12,860	☆	
	32×20	MKT322	18	12,310	☆	
	32×25	MKT321	36	12,400	☆	
	40	MKT40	12	18,880	☆	
	40×25	MKT402	16	17,620	☆	
	40×32	MKT401	16	17,940	☆	
	50	MKT50	12	26,650	☆	
	50×32	MKT502	12	25,100	☆	
50×40	MKT501	12	25,710	☆		
 メスネジアダプター	10×Rc1/2	MKMA10	192	2,610	☆	
	13×Rc1/2	MKMA13	192	2,650	☆	
	16×Rc1/2	MKMA16	192	2,750	☆	
	16×Rc3/4	MKMA162	72	3,480	☆	
	20×Rc3/4	MKMA20	72	3,930	☆	
	25×Rc1	MKMA25	54	4,950	☆	
	32×Rc1 1/4	MKMA32	36	7,090	☆	
	32×Rc1	MKMA321	36	6,080	☆	
	32×Rc3/4	MKMA322	36	6,080	☆	
	32×Rc1/2	MKMA323	36	6,600	☆	
	40×Rc1 1/2	MKMA40	24	8,650	☆	
	40×Rc1 1/4	MKMA401	24	9,000	☆	
	40×Rc1	MKMA402	24	8,940	☆	
	40×Rc3/4	MKMA403	24	10,430	☆	
	40×Rc1/2	MKMA404	24	9,650	☆	
	50×Rc2	MKMA50	18	10,300	☆	
	50×Rc1 1/2	MKMA501	18	10,560	☆	
	50×Rc1 1/4	MKMA502	18	12,190	☆	
	50×Rc1	MKMA503	18	12,790	☆	
	50×Rc3/4	MKMA504	18	12,640	☆	

品名	サイズ	品番	梱包数	価格(円/個)	改定	備考
 エルボ	13	MKL13	150	3,960	☆	
	16	MKL16	144	4,380	☆	
	20	MKL20	60	5,330	☆	
	25	MKL25	36	6,530	☆	
	32	MKL32	27	9,280	☆	
	40	MKL40	16	14,380	☆	
	50	MKL50	8	21,160	☆	
	 45°エルボ	32	MKQL32	18	10,990	☆
40		MKQL40	12	17,810	☆	
50		MKQL50	6	28,700	☆	
 キャップ	13	MKC13	144	2,030	☆	
	16	MKC16	144	2,310	☆	
	20	MKC20	144	3,000	☆	
	25	MKC25	144	3,510	☆	
	32	MKC32	90	5,070	☆	
	40	MKC40	48	6,620	☆	
	50	MKC50	36	10,170	☆	
 床出しソケット	13×Rc1/2	MKYS13S	30	5,950	☆	
 床出し調整ジョイント 45°L	13×Rc1/2	MKYC134	36	5,990	☆	
 袋ナットアダプター	13×G1/2	MKAD13	96	3,590	☆	
	16×G1/2	MKAD16	96	3,950	☆	
	20×G3/4	MKAD20	72	5,100	☆	
	25×G1	MKAD25	54	6,280	☆	
	32×G1 1/4	MKAD32	36	9,430	☆	
	40×G1 1/2	MKAD40	24	12,250	☆	
	50×G2	MKAD50	18	17,680	☆	
 継手一体型止水栓	13×G1/2	MKTS13	48	11,760	☆	
	16×G1/2	MKTS16	48	11,880	☆	
 給水栓エルボ	13×Rp1/2	MKWL13	72	4,190	☆	
	16×Rp1/2	MKWL16	72	4,250	☆	
	20×Rp1/2	MKWL20	72	4,800	☆	
 座付き給水栓エルボ	13×Rp1/2	MKWL13Z	72	5,830	☆	
	16×Rp1/2	MKWL16Z	72	6,210	☆	
	20×Rp1/2	MKWL20Z	36	6,660	☆	
 天座付き給水栓エルボ	13×Rp1/2	MKWL13D	72	7,800	☆	
 調整座金		KTCZ0	60	960		
 固定座金		KTKZ	60	1,190		

3) エスロンメタキュットRED (スーパーエスロメタックス用圧縮継手)

品名	サイズ	品番	梱包数	価格(円/個)	改定	備考
 オスネジアダプター	16×R1/2	RDOA16	84	2,580	☆	
	16×R3/4	RDOA162	72	3,000	☆	
	20×R3/4	RDOA20	72	3,330	☆	
	25×R1	RDOA25	45	4,450	☆	
	32×R1 1/4	RDOA32	36	7,900	☆	
	40×R1 1/2	RDOA40	24	12,120	☆	
	50×R2	RDOA50	24	14,460	☆	
 メスネジアダプター	16×Rc1/2	RDMA16	84	2,940	☆	
	16×Rc3/4	RDMA162	45	3,700	☆	
	20×Rc3/4	RDMA20	45	4,160	☆	
	25×Rc1	RDMA25	36	5,260	☆	
	32×Rc1 1/4	RDMA32	36	9,060	☆	
	40×Rc1 1/2	RDMA40	24	12,440	☆	
	50×Rc2	RDMA50	18	14,820	☆	
 袋ナットアダプター	16×G1/2	RDAD16	84	4,160	☆	
	20×G3/4	RDAD20	72	5,400	☆	
	25×G1	RDAD25	45	6,630	☆	
 回転オスねじアダプター	16×R3/4	RDKA162	60	7,140	☆	
	20×R3/4	RDKA20	60	7,560	☆	
	25×R1	RDKA25	48	8,550	☆	
 エルボ	16	RDL16	96	4,730	☆	
	20	RDL20	72	5,880	☆	
	25	RDL25	54	7,190	☆	
	32	RDL32	18	14,210	☆	
	40	RDL40	18	21,890	☆	
	50	RDL50	6	34,010	☆	
 45°エルボ	32	RDQL32	18	13,720	☆	
	40	RDQL40	12	19,310	☆	
	50	RDQL50	6	31,560	☆	
 チーズ	16	RDT16	48	7,780	☆	
	20	RDT20	48	8,240	☆	
	20×16	RDT201	48	9,480	☆	
	25	RDT25	36	11,240	☆	
	25×20	RDT251	18	10,210	☆	
	25×16	RDT252	36	10,040	☆	
	32	RDT32	24	18,620	☆	
	32×25	RDT321	30	17,850	☆	
	32×20	RDT322	18	17,210	☆	
	40	RDT40	16	29,070	☆	
	40×32	RDT401	16	24,340	☆	
	40×25	RDT402	16	21,870	☆	
	50	RDT50	8	40,560	☆	
	50×40	RDT501	12	34,030	☆	
50×32	RDT502	12	31,630	☆		
 メスネジチーズ	20×Rc3/4	RDMT20	36	7,780	☆	
	25×Rc1	RDMT25	18	12,310	☆	
	25×Rc3/4	RDMT251	18	11,560	☆	
	32×Rc1	RDMT321	18	16,320	☆	
	32×Rc3/4	RDMT322	30	15,150	☆	
	40×Rc1	RDMT402	12	24,250	☆	
	40×Rc3/4	RDMT403	12	25,710	☆	
	50×Rc1	RDMT503	12	30,720	☆	
50×Rc3/4	RDMT504	12	29,340	☆		

品名	サイズ	品番	梱包数	価格(円/個)	改定	備考
 ソケット	16	RDS16	84	3,950	☆	
	20	RDS20	72	5,140	☆	
	20×16	RDS201	72	6,050	☆	
	25	RDS25	45	6,180	☆	
	25×20	RDS251	45	7,260	☆	
	32	RDS32	36	9,850	☆	
	32×25	RDS321	36	10,580	☆	
	32×20	RDS322	36	9,630	☆	
	40	RDS40	32	15,680	☆	
	40×32	RDS401	32	16,250	☆	
	40×25	RDS402	16	15,020	☆	
	50	RDS50	20	20,270	☆	
 キャップ	32	RDC32	72	6,450	☆	
	40	RDC40	48	9,270	☆	
	50	RDC50	30	15,430	☆	

3) エスロンメタキュットRED (スーパーエスロメタックス用圧縮継手)

品名	サイズ	品番	梱包数	価格(円/個)	改定	備考
メタキュットRED	16,20,25	REK725K	1	625,000		
専用圧縮工具本体	32,40,50	REK750K	1	688,800		
メタキュットRED	16,20,25	REK725F	1	865,400		
専用工具フルセット (工具・ダイス・ゲージ・ バッテリー・充電器)	32,40,50	REK750F	1	1,514,500		
メタキュットRED	16	RED16	1	49,200		
専用ダイス	20	RED20	1	49,200		
(REK725K,REK750K, REK725F,REK750F 本体専用)	25	RED25	1	49,200		
	32	RED32	1	309,540		
	40	RED40	1	309,540		
	50	RED50	1	309,540		
メタキュットRED	16,20,25	REG25	1	16,900		
専用ゲージ	32,40,50	REG50	1	26,200		

関連製品 保温材付スーパーエスロメタックス
プレハブシステム

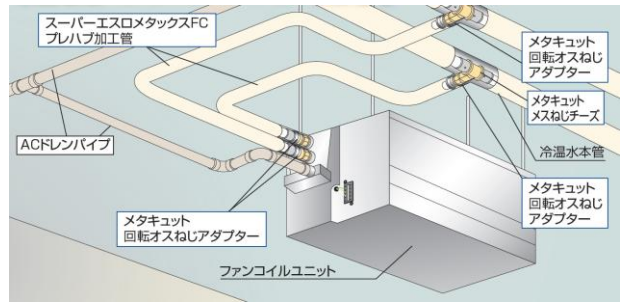

あらかじめ両管端にねじ継手をプレハブ接続。ファンコイルユニット回りの配管をプレハブ化します。

保温材付スーパーエスロメタックス プレハブ加工管			
回転オスねじアダプター	サイズ	保温厚	配管長
	16 × R3/4	10mm	1.9m～10m (0.5mきざみ) ※
		20mm	
		25mm	
	20 × R3/4	10mm	
		20mm	
		25mm	
	25 × R1	10mm	
		20mm	
		25mm	

※ 0.1mきざみの場合も特殊対応します
※**プレハブシステムは、全て受注生産品です。**まずは弊社営業所へご一報ください。

メタキュットRED用工具	
市販品	①塩ビカッター ②回し切りカッター ③プラスチックハンマー
メタキュット 共通工具	④面仕上げ器 (呼び径16～25) ⑤面取り器 RED対応 (呼び径32～50) ⑥スプリングバンダー ⑦インナーバンダー (長さ3m) ⑧プレハブバンダー
メタキュットRED 専用工具	⑨メタキュットRED専用工具セット (呼び径16～25) A メタキュットRED専用圧縮工具本体 B メタキュットRED専用ダイス C メタキュットRED専用ゲージ D 充電器 E バッテリー ⑩メタキュットRED専用工具セット (呼び径32～50) A メタキュットRED専用圧縮工具本体 B メタキュットRED専用ダイス C メタキュットRED専用ゲージ D 充電器 E バッテリー

※ 電動工具(⑨⑩)は従来のメタキュット専用工具とは互換性がありませんのでご注意ください。



4) エスロンメタッチ (スーパーエスロンメタッチ用ワンタッチ継手)

品名	サイズ	品番	梱包数	価格(円/個)	改定	備考
ソケット 	10	MTS10	120	4,300	☆	
	13	MTS13	96	4,510	☆	
	13×10	MTS131	144	4,600	☆	
	16	MTS16	108	5,240	☆	
	16×13	MTS161	108	5,050	☆	
	20	MTS20	60	6,340	☆	
	20×16	MTS201	72	6,180	☆	
エルボ 	13	MTL13	78	4,250	☆	
	16	MTL16	60	4,800	☆	
	16×13	MTL161	72	5,420	☆	
	20	MTL20	24	5,950	☆	
チーズ 	13	MTT13	45	6,220	☆	
	13×10	MTT131	45	6,100	☆	
	16	MTT16	36	7,080	☆	
	16×13	MTT161	36	6,780	☆	
	16×13×13	MTT1633	48	6,500	☆	
	16×13×16	MTT1636	36	6,830	☆	
	20	MTT20	12	8,820	☆	
	20×16	MTT201	12	8,280	☆	
	20×16×16	MTT2066	15	7,670	☆	
	20×16×20	MTT2062	12	8,290	☆	
	20×13	MTT202	18	7,920	☆	
	20×13×13	MTT2033	18	7,510	☆	
	オスネジアダプター 	10×R1/2	MTOA10	168	2,380	☆
13×R1/2		MTOA13	144	2,410	☆	
16×R1/2		MTOA16	108	2,690	☆	
16×R3/4		MTOA162	108	2,940	☆	
20×R3/4		MTOA20	72	3,320	☆	
10×G1/2		MTOA10G	168	2,380	☆	
13×G1/2		MTOA13G	144	2,410	☆	
10×R1/2		MTVA10	48	4,970	☆	
バルブ付アダプター 	13×R1/2	MTVA13	48	5,110	☆	
	16×R1/2	MTVA16	48	5,400	☆	
メスネジアダプター 	10×Rc1/2	MTMA10	120	2,640	☆	
	13×Rc1/2	MTMA13	120	2,720	☆	
	16×Rc1/2	MTMA16	108	2,870	☆	
	16×Rc3/4	MTMA162	72	3,320	☆	
	20×Rc3/4	MTMA20	72	3,720	☆	
メスネジチーズ 	16×Rc1/2	MTMT16	36	5,350	☆	
	20×Rc3/4	MTMT20	24	6,780	☆	
メスネジエルボ 	16×Rc1/2	MTML16	72	3,050	☆	
	20×Rc3/4	MTML20	30	3,910	☆	
床出しソケット 	13×Rc1/2	MTYS13S	36	4,670	☆	
給水栓エルボ 	13×Rp1/2	MTWL13	84	3,080	☆	
	16×Rp1/2	MTWL16	72	3,380	☆	
	20×Rp1/2	MTWL20	30	4,040	☆	
座付き給水栓エルボ 	13×Rp1/2	MTWL13Z	60	3,600	☆	
	16×Rp1/2	MTWL16Z	60	3,920	☆	
	20×Rp1/2	MTWL20Z	48	4,380	☆	

品名	サイズ	品番	梱包数	価格(円/個)	改定	備考
台付き給水栓エルボ 	13×Rp1/2	MTWL13D	36	4,070	☆	
	16×Rp1/2	MTWL16D	36	4,450	☆	
袋ナットアダプター 	10×G1/2	MPAD10	120	4,010	☆	
	13×G1/2	MPAD13	120	4,250	☆	
	16×G1/2	MPAD16	108	4,700	☆	
	16×G3/4	MTAD162	90	5,380	☆	
	20×G3/4	MTAD20	72	5,780	☆	
ユニオンエルボ 	10×G1/2	MTUL10	96	4,030	☆	
	13×G1/2	MTUL13	96	4,440	☆	
継手一体型止水栓 	13×G1/2	MTTS13	24	7,920	☆	
AW媒介継手 	20	MTAW20	36	6,700	☆	
AW媒介継手エルボ 	20	MTAWL20	24	7,560	☆	
回転アダプター 45°エルボ 	20	MTKA204	24	7,340	☆	

5)スーパーエスロメタックス用工具

品名	サイズ	品番	梱包数	価格(円/個)	改定	備考
塩ビカッター 		市販品				
回し切りカッター(PE管用) 		市販品				
プラスチックハンマー 		市販品				
面仕上げ器 	10	SMMZ10	100	960		
	13	SMMZ13	100	1,000		
	16	SMMZ16	100	1,200		
	20	SMMZ20	100	1,300		
	25	SMMZ25	100	1,500		
面取り器 	32	SMMT32R	30	22,440		
	40	SMMT40R	30	23,930		
	50	SMMT50R	30	25,620		
スプリングバンダー 	10	SMSB10	40	780		
	13	SMSB13	40	850		
	16	SMSB16	20	1,410		
	20	SMSB20	20	2,600		
	25	SMSB25	10	4,600		
インナーバンダー 	10	SMIB10	1	4,550		
	13	SMIB13	1	4,550		
	16	SMIB16	1	5,100		
	20	SMIB20	1	5,500		
	25	SMIB25	1	8,000		
ネオプラグ 	10	SMTTP10	60	2,500		
	13	SMTTP13	60	2,500		
	16	SMTTP16	60	2,500		
	20	SMTTP20	30	4,000		
手動式圧縮工具フルセット(工具・ダイス・ゲージ) 	10-20A用	AK20HTF	1	89,800		
小口径用電動式圧縮工具フルセット(工具・ダイス・ゲージ・バッテリー・充電器) 	10-25A用	AK725RF	1	786,340		
大口径用電動式圧縮工具セット(工具・ゲージ・バッテリー・充電器)  ※大口径用電動式圧縮工具ダイスは含まれておりません。	25-50A用	AK750RS	1	569,400		









品名	サイズ	品番	梱包数	価格(円/個)	改定	備考
大口径用電動式圧縮工具用ダイスセット 	25-50A用	AKD50RS	1	204,000		
手動式圧縮工具用ダイス 	10	AKD10HT	1	6,500		
	13	AKD13HT	1	6,500		
	16	AKD16HT	1	6,500		
	20	AKD20HT	1	6,500		
小口径用電動式圧縮工具用ダイス(AK725RF本体専用) 	10	AKD105R	1	19,700		
	13	AKD135R	1	19,700		
	16	AKD165R	1	19,700		
	20	AKD205R	1	19,700		
	25	AKD255R	1	19,700		
大口径用電動式圧縮工具用ダイス(AK750RS本体専用) 	25	AKD25R	1	49,200		
	32	AKD32R	1	49,200		
	40	AKD40R	1	49,200		
	50	AKD50R	1	49,200		
プレハブバンダー ※適用サイズを記載 	16(保温材厚20mm以下)	SMPB1	5	5,600		
	16(保温材厚25mm)/20	SMPB2	5	6,100		
	25	SMPB3	3	6,700		
充電器 		AKBC7	1	56,670		
※電動工具共用部材						
バッテリー 		AKB7	1	43,340		
※電動工具共用部材						

空調ドレン用結露防止層付硬質塩化ビニル管・樹脂継手

1) エスロンACドレンパイプ (空調ドレン用結露防止層付硬質塩化ビニル管)

品名	サイズ	品番	梱包数	価格(円/本)	改定	備考
ACドレンパイプ 長さ:4m/本 	20	ACD20P	16	4,810		
	25	ACD25P	12	5,380		
	30	ACD30P	9	6,720		
	40	ACD40P	6	8,750		
	50	ACD50P	4	11,430		
	65	ACD65P	4	15,710		

2) エスロンACドレン継手 (空調ドレン用結露防止層付硬質塩化ビニル管用継手)

品名	サイズ	品番	梱包数	価格(円/個)	改定	備考
ソケット 	20	ACS20N	120	610		
	25	ACS25N	240	660		
	30	ACS30N	160	770		
	40	ACS40N	80	1,100		
	50	ACS50N	40	1,240		
	65	ACS65N	10	1,570		
チーズ 	20	ACT20N	40	910		
	25	ACT25N	100	960		
	30	ACT30N	60	1,100		
	40	ACT40N	30	1,540		
	50	ACT50N	20	2,020		
45°Y 	30	ACY30N	30	1,820		
	40	ACY40N	25	1,960		
	50	ACY50N	14	2,090		
90°エルボ 	20	ACL20N	80	760		
	25	ACL25N	160	810		
	30	ACL30N	100	960		
	40	ACL40N	50	1,310		
	50	ACL50N	20	1,540		
径違いソケット 	25×20	ACS251N	80	630		
	30×25	ACS301N	180	770		
	40×30	ACS401N	100	1,100		
	50×40	ACS501N	60	1,240		
	65×50	ACS651N	10	1,570		
径違いY 	50×40	ACY501N	15	2,020		
径違いチーズ 	25×20	ACT251N	40	1,070		
	30×20	ACT302N	24	1,100		
	30×25	ACT301N	60	1,100		
	40×20	ACT403N	20	1,460		
	40×25	ACT402N	40	1,460		
	40×30	ACT401N	40	1,460		
	50×20	ACT504N	20	1,960		
	50×25	ACT503N	20	1,960		
	50×30	ACT502N	20	1,960		
	50×40	ACT501N	20	1,960		
	65×25	ACT654N	18	2,350		
	65×30	ACT653N	16	2,350		
	65×40	ACT652N	14	2,350		
65×50	ACT651N	12	2,350			
45°エルボ 	20	AC4L20N	80	760		
	25	AC4L25N	160	810		
	30	AC4L30N	100	960		
	40	AC4L40N	60	1,310		
	50	AC4L50N	30	1,540		
	65	AC4L65N	20	1,960		

品名	サイズ	品番	梱包数	価格(円/個)	改定	備考
アダプター 	20	ACDA20	100	340		
	25	ACDA25	80	350		
	30	ACDA30	80	420		
	40	ACDA40	50	500		
	50	ACDA50	30	560		
	65	ACDA65	10	720		
立て管用伸縮処理継手 	30	ACSS30N	6	2,220		
	40	ACSS40N	5	3,050		
	50	ACSS50N	16	3,430		
	65	ACSS65N	12	4,650		
立て型トラップ 	30	ACTT340	40	7,570		
	40	ACTT50	40	9,080		
	50	ACTT50	40	9,080		
	65	ACTT65	20	10,890		
点検口ユニット 		ACTTF35	10	4,240		
満水試験用ユニット 		ACTTM35	10	3,370		
MD継手接続アダプター 	40	ACMD40	25	1,120		
	50	ACMD50	12	1,280		

■関連部材

品名	ACドレンサイズ	品番	梱包数	価格(円/個)	改定	備考
ねじ式掃除口 	20	JNCO25N	200	550	☆	
	25	JNCO30N	200	590	☆	
	30	JNCO40N	240	590	☆	
	40	JNCO50N	132	680	☆	
	50	JNCO65N	68	1,130	☆	
	65	JNCO75N	48	1,680	☆	

3) エスロン透明ACドレン継手 (空調ドレン用結露防止層付硬質塩化ビニル管用継手)

品名	サイズ	品番	梱包数	価格(円/個)	改定	備考
ソケット	20	ACS20S	120	660		
	25	ACS25S	240	730		
	30	ACS30S	160	840		
	40	ACS40S	80	1,190		
	50	ACS50S	40	1,350		
	65	ACS65S	10	1,730		
チーズ	20	ACT20S	40	1,030		
	25	ACT25S	100	1,090		
	30	ACT30S	60	1,250		
	40	ACT40S	30	1,770		
	50	ACT50S	20	2,330		
	65	ACT65S	10	2,960		
45°Y	30	ACY30S	30	2,090		
	40	ACY40S	25	2,240		
	50	ACY50S	14	2,410		
90°エルボ	20	ACL20S	80	870		
	25	ACL25S	160	920		
	30	ACL30S	100	1,100		
	40	ACL40S	50	1,510		
	50	ACL50S	20	1,770		
	65	ACL65S	16	2,240		
径違いソケット	25×20	ACS251S	80	690		
	30×25	ACS301S	180	840		
	40×30	ACS401S	100	1,190		
	50×40	ACS501S	60	1,350		
	65×50	ACS651S	10	1,730		
径違いY	50×40	ACY501S	15	2,330		
径違いチーズ	25×20	ACT251S	40	1,220		
	30×20	ACT302S	24	1,250		
	30×25	ACT301S	60	1,250		
	40×20	ACT403S	20	1,670		
	40×25	ACT402S	40	1,670		
	40×30	ACT401S	40	1,670		
	50×20	ACT504S	20	2,230		
	50×25	ACT503S	20	2,230		
	50×30	ACT502S	20	2,230		
	50×40	ACT501S	20	2,230		
	65×25	ACT654S	18	2,960		
65×30	ACT653S	16	2,960			
65×40	ACT652S	14	2,960			
65×50	ACT651S	12	2,960			
45°エルボ	20	AC4L20S	80	870		
	25	AC4L25S	160	920		
	30	AC4L30S	100	1,100		
	40	AC4L40S	60	1,510		
	50	AC4L50S	30	1,770		
	65	AC4L65S	20	2,240		
アダプター	20	ACA20S	100	360		
	25	ACA25S	80	400		
	30	ACA30S	80	460		
	40	ACA40S	50	540		
	50	ACA50S	30	610		
	65	ACA65S	10	770		
立て管用伸縮処理継手	30	ACSS30S	6	2,540		
	40	ACSS40S	5	3,500		
	50	ACSS50S	16	3,940		
	65	ACSS65S	12	4,790		

品名	サイズ	品番	梱包数	価格(円/個)	改定	備考
立て型トラップ	30	ACTT340	40	7,570		
	40					
	50	ACTT50	40	9,080		
	65	ACTT65	20	10,890		
点検口ユニット		ACTTF35	10	4,240		
満水試験用ユニット		ACTTM35	10	3,370		
MD継手接続アダプター	40	ACMD40S	25	1,200		
	50	ACMD50S	12	1,390		
両受変換アダプター	25	ACVP25	80	550		
	30	ACVP30	80	700		

空調ドレン立て管に**新提案!**

空調ドレン立て管も
オール保温レス

立て管の伸縮処理に最適!
立て管用伸縮処理継手

- 中空断熱構造で伸縮処理継手も保温不要です。

空調配管を**しっかり防臭・防虫!**
立て型トラップ

- 自己閉鎖膜により、臭気や害虫の侵入を防ぎます。
- 点検口ユニットを簡単に取り外して内部の点検、清掃、メンテナンスも容易です。

※ 防火区画を貫通する場合は、P16の塩ビ管用フィブロックをご使用ください。



建物用耐火性硬質ポリ塩化ビニル管・継手

1) エスロン耐火VPパイプ <FS-VP>

エスロン耐火VPパイプS <FS-VP-S>・エスロン耐火VP受口付立て管 <FS-VP-RR>

品名	サイズ	品番	梱包数	価格(円/本)	改定	備考
耐火VPパイプ 長さ:4m/本 	40	FSVP404	7	5,970		
	50	FSVP504	5	7,280		
	65	FSVP654	4	10,050		
	75	FSVP754	3	12,090		
	100	FSVP1H4	2	17,610		
	125	FSVP1Q4	1	24,890		
	150	FSVP1F4	1	32,750		
	200	FSVP2H4	1	58,780		
長さ:2.9m/本	75	FSV7529	3	10,190		
	100	FSV1H29	2	14,550		
耐火VPパイプS 長さ:2.9m/本 	75	FS7529S	3	14,270		
	100	FS1H29S	2	20,530		
耐火VP受口付立て管 	75	FS7529R	1	18,040		
	100	FS1H29R	1	24,440		

2) 耐火VPパイプ用遮音カバー





品名	サイズ	品番	梱包数	価格(円/本)	改定	備考
耐火VPパイプ用 遮音カバー 	50	FSVPC50	6	5,320		
	65	FSVPC65	6	5,540		
	75	FSVPC75	6	5,700		
	100	FSVPC1H	6	5,930		
耐火ブラAD継手用 遮音カバー 	75	FSPADC	12	5,780		
	100					

品名	サイズ	品番	梱包数	価格(円/巻)	改定	備考
遮音カバー用ジョイントテープ 長さ:10m/巻 		FSVPCT	12	8,210		

3) エスロン耐火DV継手 <FS-DV>

品名	サイズ	品番	梱包数	価格(円/個)	改定	備考
ソケット(DS) 	40	FSDS40	280	700		
	50	FSDS50	160	810		
	65	FSDS65	74	970		
	75	FSDS75	70	1,070		
	100	FSDS1H	34	1,420		
	125	FSDS1Q	14	2,190		
	150	FSDS1F	12	3,250		
90°エルボ(DL) 	40	FSDL40	150	920		
	50	FSDL50	85	1,160		
	65	FSDL65	36	1,400		
	75	FSDL75	30	1,620		
	100	FSDL1H	16	2,350		
	125	FSDL1Q	8	3,540		
90°大曲りエルボ(LL) 径違い90°大曲りエルボ(LL) 	40	FSL40	110	1,490		
	50	FSL50	56	1,670		
	65	FSL65	26	2,000		
	75	FSL75	22	2,350		
	100	FSL1H	10	3,320		
	100×75	FSL1H1	12	3,640		
	125	FSL1Q	5	4,740		
	150	FSL1F	4	7,280		

3) エスロン耐火DV継手 <FS-DV>

品名	サイズ	品番	梱包数	価格(円/個)	改定	備考
45°エルボ(45L) 	40	FS4L40	190	890		
	50	FS4L50	100	1,050		
	65	FS4L65	46	1,300		
	75	FS4L75	40	1,450		
	100	FS4L1H	20	2,020		
	125	FS4L1Q	10	3,170		
	150	FS4L1F	6	4,430		
	90°Y(DT) 径違い90°Y(DT) 	40	FSDT40	100	910	
50		FSDT50	50	1,460		
65		FSDT65	24	1,900		
75		FSDT75	24	2,270		
100		FSDT1H	12	3,410		
125		FSDT1Q	6	5,300		
150		FSDT1F	4	8,720		
50×40		FSDT501	66	1,400		
65×40		FSDT652	40	1,520		
65×50		FSDT651	34	1,790		
75×40		FSDT753	34	1,520		
75×50		FSDT752	34	1,930		
75×65		FSDT751	30	2,130		
100×40		FSDT1H4	24	2,440		
100×50		FSDT1H3	22	2,570		
100×65		FSDT1H2	16	2,830		
100×75		FSDT1H1	14	2,990		
125×100	FSDT1Q1	8	4,740			
150×100	FSDT1F2	6	7,690			
90°大曲りY(LT) 径違い90°大曲りY(LT) 	40	FSLT40	70	1,460		
	50	FSLT50	34	1,650		
	65	FSLT65Y	16	2,150		
	75	FSLT75	16	2,500		
	100	FSLT1H	8	3,830		
	125	FSLT1Q	4	5,980		
	150	FSLT1F	3	10,100		
	50×40	FSLT501	46	1,550		
	65×40	FSLT652	30	1,930		
	65×50	FSLT651Y	22	1,940		
	75×40	FSLT753	30	2,000		
	75×50	FSLT752	26	2,150		
	75×65	FSLT751	20	2,390		
	100×40	FSLT1H4	18	2,700		
	100×50	FSLT1H3	14	2,900		
	100×65	FSLT1H2	12	3,170		
	100×75	FSLT1H1	12	3,330		
125×75	FSLT1Q2	6	3,910			
125×100	FSLT1Q1	4	5,430			
45°Y(Y) 径違い45°Y(Y) 	40	FSY40	70	1,400		
	50	FSY50	40	1,520		
	65	FSY65Y	18	1,970		
	75	FSY75	16	2,300		
	100	FSY1H	8	3,540		
	125	FSY1Q	4	5,800		
	150	FSY1F	3	9,990		
	50×40	FSY501	50	1,330		
	65×40	FSY652	30	1,420		
	65×50	FSY651Y	24	1,760		
	75×40	FSY753	32	1,840		
	75×50	FSY752	26	1,990		
	75×65	FSY751	20	2,180		
100×40	FSY1H4	22	2,660			
100×50	FSY1H3	16	2,850			
100×65	FSY1H2	14	2,900			
100×75	FSY1H1	10	3,270			
125×100	FSY1Q1	5	5,260			
150×100	FSY1F2	4	7,490			







3) エスロン耐火DV継手 <FS-DV>

品名	サイズ	品番	梱包数	価格(円/個)	改定	備考
インクリーザ(IN) 	50 × 40	FSIN501	150	780		
	65 × 40	FSIN652	130	830		
	65 × 50	FSIN651	100	890		
	75 × 40	FSIN753	120	910		
	75 × 50	FSIN752	120	980		
	75 × 65	FSIN751	90	1,070		
	100 × 40	FSIN1H4	54	1,080		
	100 × 50	FSIN1H3	54	1,140		
	100 × 65	FSIN1H2	54	1,270		
	100 × 75	FSIN1H1	48	1,330		
	125 × 75	FSIN1Q2	28	1,820		
	125 × 100	FSIN1Q1	25	2,280		
	150 × 100	FSIN1F2	20	3,490		
150 × 125	FSIN1F1	18	3,610			
偏芯インクリーザ(IN) 	50 × 40	FSIH501	150	870		
	65 × 50	FSIH651	80	990		
90°大曲り両Y(WLT) 	100 × 75	FSWT1H1	6	7,910		
	125 × 100	FSWT1Q1	3	11,070		
コンパクト掃除口付継手 	75	FSCT75	28	5,820		
	100	FSCT1H	14	6,460		
差込ソケット(ES) 	40	FSSS40	120	1,650		
	50	FSSS50	75	1,720		
	65	FSSS65	40	1,770		
	75	FSSS75	45	1,800		
	100	FSSS1H	16	2,520		
	125	FSSS1Q	12	4,690		
Sソケット 	40	FSDSS40	85	1,800		
	50	FSDSS50	60	2,000		
	65	FSDSS65	30	2,200		
	75	FSDSS75	18	2,400		
	100	FSDSS1H	15	3,300		
	ねじ式掃除口(NCO) 	40	FSCO40	120	880	
50		FSCO50	132	920		
65		FSCO65	68	1,070		
75		FSCO75	48	1,200		
100		FSCO1H	24	1,770		
125		FSCO1Q	20	6,850		
150		FSCO1F	9	9,960		
200		FSCO2H	4	22,310		
やりとりソケット(LES) 	40	FSYS40	102	1,750		
	50	FSYS50	60	2,080		
	65	FSYS65	28	2,640		
	75	FSYS75	22	2,840		
	100	FSYS1H	11	4,040		
	125	FSYS1Q	6	5,950		
排水用バルブソケット(VS) 	40	FSVS40	200	640		
	50	FSVS50	180	790		
	65	FSVS65	96	890		
	75	FSVS75	90	1,050		
	100	FSVS1H	44	1,520		

4) エスロン透明耐火DV継手 <FS-DV>

品名	サイズ	品番	梱包数	価格(円/個)	改定	備考
ソケット(DS) 	40	SFDS40	280	780		
	50	SFDS50	160	890		
	65	SFDS65	74	1,070		
	75	SFDS75	70	1,170		
	100	SFDS1H	34	1,560		
	125	SFDS1Q	14	2,410		
	150	SFDS1F	12	3,580		
	200	SFDS2H	3	20,280		
90°エルボ(DL) 	40	SFDL40	150	1,010		
	50	SFDL50	85	1,270		
	65	SFDL65	36	1,540		
	75	SFDL75	30	1,770		
	100	SFDL1H	16	2,600		
	125	SFDL1Q	8	3,910		
	150	SFDL1F	5	6,070		
	200	SFDL2H	2	32,450		
90°大曲りエルボ(LL) 径違い90°大曲りエルボ(LL) 	40	SFLL40	110	1,640		
	50	SFLL50	56	1,840		
	65	SFLL65	26	2,210		
	75	SFLL75	22	2,600		
	100	SFLL1H	10	3,650		
	100 × 75	SFLL1H1	12	4,000		
	125	SFLL1Q	5	5,200		
	150	SFLL1F	4	8,010		
45°エルボ(45L) 	40	SF4L40	190	980		
	50	SF4L50	100	1,140		
	65	SF4L65	46	1,420		
	75	SF4L75	40	1,580		
	100	SF4L1H	20	2,230		
	125	SF4L1Q	10	3,490		
90°Y(DT) 径違い90°Y(DT) 	40	SFDT40	100	1,000		
	50	SFDT50	50	1,620		
	65	SFDT65	24	2,090		
	75	SFDT75	24	2,500		
	100	SFDT1H	12	3,750		
	125	SFDT1Q	6	5,840		
	150	SFDT1F	4	9,590		
	200	SFDT2H	1	49,680		
	50 × 40	SFDT501	66	1,540		
	65 × 40	SFDT652	40	1,670		
	65 × 50	SFDT651	34	1,970		
	75 × 40	SFDT753	34	1,670		
	75 × 50	SFDT752	34	2,120		
	75 × 65	SFDT751	30	2,340		
	100 × 40	SFDT1H4	24	2,680		
	100 × 50	SFDT1H3	22	2,830		
100 × 65	SFDT1H2	16	3,100			
100 × 75	SFDT1H1	14	3,290			
125 × 100	SFDT1Q1	8	5,200			
150 × 100	SFDT1F2	6	8,460			

4) エスロン透明耐火DV継手 <FS-DV>

品名	サイズ	品番	梱包数	価格(円/個)	改定	備考
90°大曲りY(LT) 径違い90°大曲りY(LT) 	40	SFLT40	70	1,620		
	50	SFLT50	34	1,820		
	65	SFLT65Y	16	2,350		
	75	SFLT75	16	2,750		
	100	SFLT1H	8	4,200		
	125	SFLT1Q	4	6,580		
	150	SFLT1F	3	11,110		
	200	SFLT2H	1	58,820		
	50×40	SFLT501	46	1,710		
	65×40	SFLT652	30	2,120		
	65×50	SFLT61Y	22	2,130		
	75×40	SFLT753	30	2,210		
	75×50	SFLT752	26	2,350		
	75×65	SFLT751	20	2,630		
	100×40	SFLT1H4	18	2,970		
	100×50	SFLT1H3	14	3,190		
	100×65	SFLT1H2	12	3,490		
	100×75	SFLT1H1	12	3,660		
	125×75	SFLT1Q2	6	4,290		
	125×100	SFLT1Q1	4	5,970		
200×150	SFLT2H1	1	56,780			
45°Y(Y) 径違い45°Y(Y) 	40	SFY40	70	1,540		
	50	SFY50	40	1,670		
	65	SFY65Y	18	2,170		
	75	SFY75	16	2,520		
	100	SFY1H	8	3,910		
	125	SFY1Q	4	6,380		
	150	SFY1F	3	10,990		
	200	SFY2H	1	56,780		
	50×40	SFY501	50	1,470		
	65×40	SFY652	30	1,560		
	65×50	SFY651Y	24	1,940		
	75×40	SFY753	32	2,020		
	75×50	SFY752	26	2,190		
	75×65	SFY751	20	2,400		
	100×40	SFY1H4	22	2,930		
	100×50	SFY1H3	16	3,150		
100×65	SFY1H2	14	3,190			
100×75	SFY1H1	10	3,600			
125×100	SFY1Q1	5	5,790			
150×100	SFY1F2	4	8,240			
インクリーザ(IN) 	50×40	SFIN501	150	860		
	65×40	SFIN652	130	910		
	65×50	SFIN651	100	980		
	75×40	SFIN753	120	1,000		
	75×50	SFIN752	120	1,080		
	75×65	SFIN751	90	1,170		
	100×40	SFIN1H4	54	1,200		
	100×50	SFIN1H3	54	1,250		
	100×65	SFIN1H2	54	1,400		
	100×75	SFIN1H1	48	1,470		
	125×75	SFIN1Q2	28	1,990		
	125×100	SFIN1Q1	25	2,510		
150×100	SFIN1F2	20	3,840			
150×125	SFIN1F1	18	3,980			
偏芯インクリーザ(IN) 	50×40	SFIH501	150	960		
	65×50	SFIH651	80	1,090		
プッシュ(BU) 	200×150	SFBU2H1	6	23,320		
90°大曲り両Y(WLT) 	100×75	SFWT1H1	6	8,710		
	125×100	SFWT1Q1	3	12,170		

品名	サイズ	品番	梱包数	価格(円/個)	改定	備考
コンパクト掃除口付継手 	75	SFCT75	28	6,400		
	100	SFCT1H	14	7,110		
差込ソケット(ES) 	40	SFSS40	120	1,820		
	50	SFSS50	75	1,890		
	65	SFSS65	40	1,960		
	75	SFSS75	45	1,980		
	100	SFSS1H	16	2,770		
	125	SFSS1Q	12	5,160		
Sソケット 	40	SFDSS40	85	2,000		
	50	SFDSS50	60	2,200		
	65	SFDSS65	30	2,400		
	75	SFDSS75	18	2,600		
	100	SFDSS1H	15	3,600		
やりとりソケット(LES) 	40	SFYS40	102	1,930		
	50	SFYS50	60	2,280		
	65	SFYS65	28	2,900		
	75	SFYS75	22	3,110		
	100	SFYS1H	11	4,440		
	125	SFYS1Q	6	6,550		
排水用バルブソケット(VS) 	40	SFVS40	200	700		
	50	SFVS50	180	880		
	65	SFVS65	96	980		
	75	SFVS75	90	1,160		
	100	SFVS1H	44	1,670		

5) コンパクト掃除口付継手用遮音カバー

品名	サイズ	品番	梱包数	価格(円/本)	改定	備考
コンパクト掃除口付継手用遮音カバー 	75	FCSCO75	12	5,630		
	100	FCSCO1H	12	5,700		

6) エスロン耐火DV遮音継手

品名	サイズ	品番	梱包数	価格(円/個)	改定	備考
掃除口(CO) 	50	FZCO50	12	1,830		
	65	FZCO65	8	1,900		
	75	FZCO75	12	1,970		
90°Y(DT) 	50	FZDT50	8	2,770		
	65	FZDT65	5	3,140		
	75	FZDT75	8	3,280		
ソケット(DS) 	50	FZDS50	18	1,540		
	65	FZDS65	12	1,670		
	75	FZDS75	8	1,900		
	100	FZDS1H	6	2,490		
45°エルボ(45L) 	75	FZ4L75	8	2,330		
	100	FZ4L1H	6	3,280		
90°大曲りエルボ(LL) 	75	FZLL75	6	3,860		
	100	FZLL1H	2	5,390		

6) エスロン耐火DV遮音継手

品名	サイズ	品番	梱包数	価格(円/個)	改定	備考
90°大曲Y(LT) 	50	FZLT50	6	3,140		
	65	FZLT65	2	3,580		
	75	FZLT75	3	3,860		
45°Y(Y) 	50	FZY50	6	3,070		
	65	FZY65	2	3,420		
	75	FZY75	4	3,780		
	100	FZY1H	2	6,270		
差込ソケット(ES) 	50	FZSS50	11	3,860		
	65	FZSS65	6	4,810		
	75	FZSS75	6	5,100		
	100	FZSS1H	3	6,270		
径違い90°Y(DT) 	65×50	FZDT651	5	3,070		
	75×50	FZDT752	9	3,140		
	75×65	FZDT751	9	3,200		
	100×65	FZDT1H2	4	4,240		
	100×75	FZDT1H1	4	4,370		
径違い90°大曲Y(LT) 	50×40	FZLT501	6	2,920		
	65×50	FZLT651	3	3,420		
	75×50	FZLT752	7	3,580		
	75×65	FZLT751	4	3,710		
	100×65	FZLT1H2	2	5,030		
	100×75	FZLT1H1	2	5,170		
Yチース(YT) 	75×65	FZY751	6	3,650		
	100×75	FZY1H1	2	5,100		
耐火VPサニタリーバンド (アイボリー色) ストレート 	75	FSPSBS	8	3,490		※1
耐火VPサニタリーバンド (アイボリー色) 10° 	75	FSPSB10	8	3,800		※1
耐火VPサニタリーバンド (アイボリー色) 80° 	75	FSPSB80	6	9,490		※1
耐火VPサニタリーバンド (アイボリー色) 90°(L450) 90°(L630) 	75	FSPSB94	8	5,060		※1
	75	FSPSB96	8	6,330		※1
カラーパイプ サニタリーバンド 80° 	75	JPSB80	6	8,730		※2

※1. 耐火VP仕様(アイボリー色)。防火区画で耐火VPの認定が必要な場合、必ず耐火VPサニタリーバンドを使用してください

※2. ノーマルVP仕様

7) エスロン耐火プラADミニ継手<FS-PAD-M>

品名	サイズ	品番	梱包数	価格(円/個)	改定	備考
呼び径75(無流入) ミニ継手 	75	PDM7	4	8,230		※1
呼び径75(無流入) ミニ継手 ロングタイプ 	75	PDML7	1	11,130		
呼び径75(1方向) ミニ継手 	75-50	PDM75	4	8,230		
呼び径75(1方向) ミニ継手 ロングタイプ 	75-50	PDML75	1	11,130		
呼び径100(無流入) ミニ継手 	100	PDM1	2	10,120		※1
呼び径100(無流入) ミニ継手 ロングタイプ 	100	PDML1	1	13,040		
呼び径100(1方向) ミニ継手 	100-50	PDM105	2	10,120		
	100-50	PDM15	2	10,120		※1
	100-65	PDM106	2	10,120		
	100-65	PDM16	2	10,120		※1
	100-75	PDM107	2	10,120		
	100-75	PDM17	2	10,120		※1
呼び径100(1方向) ミニ継手 ロングタイプ 	100-50	PDML105	1	13,040		
	100-65	PDML106	1	13,040		
	100-75	PDML107	1	13,040		
呼び径100(2方向) ミニ継手 	100-50×50	PDM155	2	12,020		※1
	100-65×50	PDM165	2	12,020		※1.2
	100-50×65	PDM156	2	12,020		※1.3
	100-65×65	PDM166	2	12,020		※1
	100-75×50	PDM175	2	12,020		※2
	100-50×75	PDM157	2	12,020		※3
	100-75×65	PDM176	2	12,020		※2
	100-65×75	PDM167	2	12,020		※3
	100-75×75	PDM177	2	12,020		
呼び径100(2方向) ミニ継手ロングタイプ 	100-50×50	PDML155	1	14,930		
	100-65×50	PDML165	1	14,930		※2
	100-50×65	PDML156	1	14,930		※3
	100-65×65	PDML166	1	14,930		
	100-75×50	PDML175	1	14,930		※2
	100-50×75	PDML157	1	14,930		※3
	100-75×65	PDML176	1	14,930		※2
	100-65×75	PDML167	1	14,930		※3
	100-75×75	PDML177	1	14,930		

※1. 受注生産品です

※2. 右記図面のように、横枝管の最大管径が上面から見て左側になります

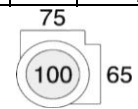

※3. 右記図面のように、横枝管の最大管径が上面から見て右側になります

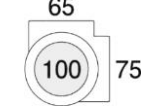

8) エスロン耐火ブラAD継手HG-SG

(1) エスロン耐火ブラAD継手HG

立て管100A	1枝	2枝 90°	2枝 180°	3枝						梱包数
受口価格(円/個)	23,410	25,300	25,300	27,200						1
差口価格(円/個)	23,410	25,300	25,300	27,200						
改定										
 <p>HG (ハイグレード) ※写真は 3枝の場合</p>										
	HG15U★	HG155U	HG116U	HG1505U	HG1106U	HG1555U	HG1516U	HG1677U	HG1761U	
	HG15S★	HG155S	HG116S	HG1505S	HG1106S	HG1555S	HG1516S	HG1677S	HG1761S	
										
	HG16U★	HG156U	HG117U	HG1506U	HG1107U	HG1556U	HG1517U	HG1671U	HG1775U	
	HG16S★	HG156S	HG117S	HG1506S	HG1107S	HG1556S	HG1517S	HG1671S	HG1775S	
										
	HG17U★	HG157U★	HG111U	HG1507U	HG1101U	HG1557U	HG1511U	HG1615U	HG1776U	
	HG17S★	HG157S	HG111S	HG1507S	HG1101S	HG1557S	HG1511S	HG1615S	HG1776S	
										
	HG11U★	HG151U		HG1501U		HG1551U	HG1655U	HG1616U	HG1777U	
	HG11S	HG151S		HG1501S		HG1551S	HG1655S	HG1616S	HG1777S	
										
		HG165U		HG1605U		HG1565U	HG1656U	HG1617U	HG1771U	
		HG165S		HG1605S		HG1565S	HG1656S	HG1617S	HG1771S	
										
		HG166U		HG1606U		HG1566U	HG1657U	HG1611U	HG1715U	
		HG166S		HG1606S		HG1566S	HG1657S	HG1611S	HG1715S	
										
		HG167U★		HG1607U		HG1567U	HG1651U	HG1755U	HG1716U	
		HG167S★		HG1607S		HG1567S	HG1651S	HG1755S	HG1716S	
										
		HG161U		HG1601U		HG1561U	HG1665U	HG1756U	HG1717U	
		HG161S		HG1601S		HG1561S	HG1665S	HG1756S	HG1717S	
										
		HG175U★		HG1705U		HG1575U	HG1666U	HG1757U	HG1711U	
		HG175S		HG1705S		HG1575S	HG1666S	HG1757S	HG1711S	
										
		HG176U★		HG1706U		HG1576U★	HG1667U	HG1751U		
		HG176S★		HG1706S		HG1576S	HG1667S	HG1751S		
										
	HG177U★		HG1707U		HG1577U	HG1661U	HG1765U			
	HG177S		HG1707S		HG1577S	HG1661S	HG1765S			
										
	HG171U		HG1701U		HG1571U	HG1675U★	HG1766U			
	HG171S		HG1701S		HG1571S	HG1675S	HG1766S			
										
	HG115U		HG1105U		HG1515U	HG1676U	HG1767U			
	HG115S		HG1105S		HG1515S	HG1676S	HG1767S			

※1. ★は標準品です。その他は受注生産品となります

※2. 便器排水の流入口対面に横枝管を接続しないでください















































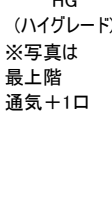

































































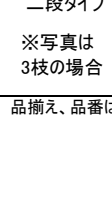

















※3. 本体枝下の延長により、厚スラブでの施工が可能です

差口M: 品番末尾のSをMに変えてください。上表価格の6,000円加算となります

差口L: 品番末尾のSをLに変えてください。上表価格の8,000円加算となります

差口Oと差口Iは全て受注生産品です

(1)エスロン耐火ブラAD継手HG

立て管100A	3枝	0枝	最上階 通気+1口	最上階 通気+2口					梱包数
受口価格(円/個)	27,200	23,410	25,300	27,200					1
差口価格(円/個)	27,200	23,410	25,300	27,200					
改定									
 HG (ハイグレード) ※写真は 3枝の場合	 HG1155U	 HG1175U	 HG1U	 HU151U	 HU1551U	 HU1661U	 HU1771U	 HU1151U	 HU1171U
	 HG1155S	 HG1175S	 HG1S	 HU151S	 HU1551S	 HU1661S	 HU1771S	 HU1151S	 HU1171S
 HG (ハイグレード) ※写真は 最上階 通気+1口	 HG1156U	 HG1176U		 HU161U	 HU1561U	 HU1671U	 HU1715U	 HU1165U	 HU1115U
	 HG1156S	 HG1176S		 HU161S	 HU1561S	 HU1671S	 HU1715S	 HU1165S	 HU1115S
 HG (ハイグレード) ※写真は 最上階 通気+1口	 HG1157U	 HG1177U		 HU171U	 HU1571U	 HU1615U	 HU1716U	 HU1166U	 HU1116U
	 HG1157S	 HG1177S		 HU171S	 HU1571S	 HU1615S	 HU1716S	 HU1166S	 HU1116S
 HG (ハイグレード) ※写真は 最上階 通気+1口	 HG1151U	 HG1171U		 HU115U	 HU1515U	 HU1616U	 HU1717U	 HU1167U	 HU1117U
	 HG1151S	 HG1171S		 HU115S	 HU1515S	 HU1616S	 HU1717S	 HU1167S	 HU1117S
 HG (ハイグレード) ※写真は 最上階 通気+1口	 HG1165U	 HG1115U		 HU116U	 HU1516U	 HU1617U	 HU1711U	 HU1161U	 HU1111U
	 HG1165S	 HG1115S		 HU116S	 HU1516S	 HU1617S	 HU1711S	 HU1161S	 HU1111S
 HG (ハイグレード) ※写真は 最上階 通気+1口	 HG1166U	 HG1116U		 HU117U	 HU1517U	 HU1611U	 HU1155U	 HU1175U	
	 HG1166S	 HG1116S		 HU117S	 HU1517S	 HU1611S	 HU1155S	 HU1175S	
 HG (ハイグレード) ※写真は 最上階 通気+1口	 HG1167U	 HG1117U		 HU111U	 HU1511U	 HU1751U	 HU1156U	 HU1176U	
	 HG1167S	 HG1117S		 HU111S	 HU1511S	 HU1751S	 HU1156S	 HU1176S	
 HG (ハイグレード) ※写真は 最上階 通気+1口	 HG1161U	 HG1111U			 HU1651U	 HU1761U	 HU1157U	 HU1177U	
	 HG1161S	 HG1111S			 HU1651S	 HU1761S	 HU1157S	 HU1177S	

※1. ★は標準品です。その他は受注生産品となります

※2. 便器排水の流入口対面に横枝管を接続しないでください

※3. 本体枝下の延長により、厚スラブでの施工が可能です

差口M: 品番末尾のSをMに変えてください。上表価格の6,000円加算となります





















































































































差口L: 品番末尾のSをLに変えてください。上表価格の8,000円加算となります

差口Mと差口Lは全て受注生産品です

立て管100A	上段	下段		上段枝高さ (単位: mm)	価格(円/個)	改定
	呼び径	横枝管	呼び径			
 HG (ハイグレード) 二段タイプ ※写真は 3枝の場合	75	0枝	—	235 245 255 265 275 285 295 305 315 325 335	43,010	
		1枝	75, 65, 50			
		2枝	75 × 75, 75 × 65, 75 × 50			
			65 × 65, 65 × 50 50 × 50			
		3枝	75 × 75 × 75, 75 × 75 × 65, 75 × 75 × 50			
			75 × 65 × 65, 75 × 65 × 50			
	75 × 50 × 50					
	65 × 65 × 65, 65 × 65 × 50 65 × 50 × 50 50 × 50 × 50					





























































































※ 品揃え、品番はエスロン耐火ブラAD継手・ADスリム継手価格表をご参照ください

(1)エスロン耐火ブラD継手HG

立て管100A	最下階 1枝	最下階 2枝 90°	最下階 2枝 180°	最下階 3枝				最下階 0枝	梱包数
差口価格(円/個)	23,410	25,300	25,300	27,200				23,410	1
改定									
 <p>HG (ハイグレード) ※写真は 最下階 3枝の場合</p>									
	HL15S★	HL155S	HL1505S	HL1555S	HL1655S	HL1755S	HL1155S	HL1S	
									
	HL16S★	HL156S	HL1506S	HL1556S	HL1656S	HL1756S	HL1156S		
									
	HL17S★	HL157S	HL1507S	HL1557S	HL1657S	HL1757S	HL1157S		
									
	HL11S★	HL151S	HL1501S	HL1551S	HL1651S	HL1751S	HL1151S		
									
		HL165S	HL1605S	HL1565S	HL1665S	HL1765S	HL1165S		
									
		HL166S	HL1606S	HL1566S	HL1666S	HL1766S	HL1166S		
									
		HL167S★	HL1607S	HL1567S	HL1667S	HL1767S	HL1167S		
									
		HL161S	HL1601S	HL1561S	HL1661S	HL1761S	HL1161S		
									
		HL175S	HL1705S	HL1575S	HL1675S	HL1775S	HL1175S		
									
		HL176S★	HL1706S	HL1576S	HL1676S	HL1776S	HL1176S		
									
		HL177S★	HL1707S	HL1577S	HL1677S	HL1777S	HL1177S		
									
		HL171S	HL1701S	HL1571S	HL1671S	HL1771S	HL1171S		
									
		HL115S	HL1105S	HL1515S	HL1615S	HL1715S	HL1115S		
									
		HL116S	HL1106S	HL1516S	HL1616S	HL1716S	HL1116S		
									
	HL117S	HL1107S	HL1517S	HL1617S	HL1717S	HL1117S			
									
	HL111S	HL1101S	HL1511S	HL1611S	HL1711S	HL1111S			

※1. ★は標準品です。その他は受注生産品となります
 ※2. 便器排水の流入口対面に横枝管を接続しないでください



















































(1)エスロン耐火ブラAD継手HG

立て管75A	1枝	2枝 90°	2枝 180°	3枝			0枝	最上階 通気+1口	最上階 通気+2口	梱包数
受口価格 (円/個)	22,140	24,040	24,040	25,940			22,140	24,040	25,940	1
差口価格 (円/個)	22,140	24,040	24,040	25,940			22,140	24,040	25,940	
改定										
 <p>HG (ハイグレード) ※写真は 3枝の場合</p>										
	HG75S	HG755S	HG7505S	HG7555S	HG7666S	HG7777S	HG7S	HU757S	HU7557S	HU7765S
										
	HG76S	HG756S	HG7506S	HG7556S	HG7667S			HU767S	HU7567S	HU7766S
										
	HG77S	HG757S	HG7507S	HG7557S	HG7675S			HU775S	HU7575S	HU7767S
										
	HG765S	HG7605S	HG7565S	HG7556S	HG7676S			HU776S	HU7576S	HU7775S
										
	HG766S	HG7606S	HG7566S	HG7566S	HG7677S			HU777S	HU7577S	HU7776S
										
	HG767S	HG7607S	HG7567S	HG7567S	HG7755S			HU7657S	HU7777S	
										
	HG775S	HG7705S	HG7575S	HG7575S	HG7756S			HU7667S		
										
	HG776S	HG7706S	HG7576S	HG7576S	HG7757S			HU7675S		
										
	HG777S	HG7707S	HG7577S	HG7577S	HG7765S			HU7676S		
										
	HG7655S	HG76055S	HG75655S	HG75565S	HG7766S			HU7677S		
										
	HG7656S	HG76066S	HG75666S	HG75666S	HG7767S			HU7755S		
										
	HG7657S	HG76077S	HG75677S	HG75677S	HG7775S			HU7756S		
										
	HG7665S	HG76065S	HG75665S	HG75665S	HG7776S			HU7757S		

※1. ★は標準品です。その他は受注生産品となります
 ※2. 便器排水の流入口対面に横枝管を接続しないでください

※3. 本体枝下の延長により、厚スラブでの施工が可能です
 差口M: 品番末尾のSをMに変えてください。上表価格の6,000円加算となります
 差口Mは全て受注生産品です

(1)エロン耐火ブラAD継手HG

立て管75A	最下階 1枝	最下階 2枝 90°	最下階 2枝 180°	最下階 3枝		最下階 0枝	梱包数
差口価格(円/個)	22,140	24,040	24,040	25,940		22,140	1
改定							
 <p>HG (ハイグレード) ※写真は 最下階 3枝の場合</p>							
	HL75S★	HL755S	HL7505S	HL7555S	HL7676S	HL7S	
							
	HL76S	HL756S	HL7506S	HL7556S	HL7677S		
							
	HL77S	HL757S	HL7507S	HL7557S	HL7755S		
							
		HL765S	HL7605S	HL7565S	HL7756S		
							
		HL766S	HL7606S	HL7566S	HL7757S		
							
		HL767S	HL7607S	HL7567S	HL7765S		
							
		HL775S	HL7705S	HL7575S	HL7766S		
							
		HL776S	HL7706S	HL7576S	HL7767S		
							
		HL777S	HL7707S	HL7577S	HL7775S		
							
				HL7655S	HL7776S		
							
				HL7656S	HL7777S		
							
				HL7657S			
							
				HL7665S			
							
			HL7666S				
							
			HL7667S				
							
			HL7675S				



















































※1. ★は標準品です。その他は受注生産品となります
 ※2. 便器排水の流入口対面に横枝管を接続しないでください

(2) エスロン耐火ブラAD継手SG

立て管100A	1枝	2枝 90°	2枝 180°	3枝							0枝	梱包数	
受口価格 (円/個)	18,350	20,240	20,240	22,140							18,350	1	
改定													
 <p>SG (スタンダード グレード)</p>													
	SG15U★	SG155U	SG116U	SG1505U	SG1106U	SG1555U	SG1516U	SG1677U	SG1761U	SG1165U	SG1U		
	SG16U★	SG156U	SG117U	SG1506U	SG1107U	SG1556U	SG1517U	SG1671U	SG1775U	SG1166U			
	SG17U★	SG157U	SG111U	SG1507U	SG1101U	SG1557U	SG1511U	SG1615U	SG1776U	SG1167U			
	SG11U	SG151U		SG1501U		SG1551U	SG1655U	SG1616U	SG1777U	SG1161U			
	SG165U			SG1605U		SG1565U	SG1666U	SG1617U	SG1771U	SG1175U			
	SG166U			SG1606U		SG1566U	SG1657U	SG1611U	SG1715U	SG1176U			
	SG167U★			SG1607U		SG1567U	SG1651U	SG1755U	SG1716U	SG1177U			
	SG161U			SG1601U		SG1561U	SG1665U	SG1756U	SG1717U	SG1171U			
	SG175U			SG1705U		SG1575U	SG1666U	SG1757U	SG1711U	SG1115U			
	SG176U★			SG1706U		SG1576U	SG1667U	SG1751U	SG1155U	SG1116U			
	SG177U★			SG1707U		SG1577U	SG1661U	SG1765U	SG1156U	SG1117U			
	SG171U			SG1701U		SG1571U	SG1675U	SG1766U	SG1157U	SG1111U			
	SG115U			SG1105U		SG1515U	SG1676U	SG1767U	SG1151U				

※1. ★は標準品です。その他は受注生産品となります
 ※2. 便器排水の流入口対面に横枝管を接続しないでください
 ※3. 耐火ブラAD継手 SGの最上階継手品揃えはありません

(2) エスロン耐火ブラAD継手SG

立て管75A	1枝	2枝 90°	2枝 180°	3枝			0枝	梱包数	
受口価格(円/個)	17,080	18,980	18,980	20,880			17,080	1	
改定									
 <p>SG (スタンダード グレード) ※写真は 3枝の場合</p>									
	SG75U★	SG755U	SG7505U	SG7555U	SG7666U	SG7777U	SG7U		
	-	-	-	-	-	-	-	-	
									
	SG76U	SG756U	SG7506U	SG7556U	SG7667U				
	-	-	-	-	-				
									
	SG77U	SG757U	SG7507U	SG7557U	SG7675U				
	-	-	-	-	-				
									
		SG765U	SG7605U	SG7565U	SG7676U				
	-	-	-	-	-				
									
		SG766U	SG7606U	SG7566U	SG7677U				
	-	-	-	-	-				
									
		SG767U	SG7607U	SG7567U	SG7755U				
	-	-	-	-	-				
									
		SG775U	SG7705U	SG7575U	SG7756U				
	-	-	-	-	-				
									
		SG776U	SG7706U	SG7576U	SG7757U				
	-	-	-	-	-				
									
		SG777U	SG7707U	SG7577U	SG7765U				
-	-	-	-	-					
									
			SG7655U	SG7766U					
-	-	-	-	-					
									
			SG7656U	SG7767U					
-	-	-	-	-					
									
			SG7657U	SG7775U					
-	-	-	-	-					
									
			SG7665U	SG7776U					
-	-	-	-	-					

※1. ★は標準品です。その他は受注生産品となります
 ※2. 便器排水の流入口対面に横枝管を接続しないでください
 ※3. 耐火ブラAD継手 SGの最上階継手品揃えはありません

(3)耐火ブラAD継手付属品

品名	サイズ	品番	梱包数	価格(円/本)	改定	備考
エスロンパイプ・ + (プラス) 長さ:4m/本  長さ:2.9m/本	40	VP404	7	3,430		
	50	VP504	5	4,840		
	65	VP654	5	6,170		
	75	VP754	3	9,470		
	100	VP1H4	2	13,920		
	125	VP1Q4	2	17,860		
	150	VP1F4	1	26,810		
	75	VP7529	3	7,820		
VPパイプS 2.9m/本 	75	VP7529S	3	9,870		
	100	VP1H29S	2	13,820		
VP受口付立て管 2.8m/本 	75	VP7529R	1	10,630		
	100	VP1H29R	1	15,180		

品名	サイズ	品番	梱包数	価格(円/本)	改定	備考
VPパイプ用遮音カバー 	75	VPC75	6	5,700		
	100	VPC1H	6	5,930		

品名	サイズ	品番	梱包数	価格(円/巻)	改定	備考
遮音カバー用 ジョイントテープ 10m/巻 		FSPVCT	12	8,210		

(4)プラ脚部継手

品名	サイズ	品番	梱包数	価格(円/個)	改定	備考
プラ脚部継手 ※1 通常グレード 標準 	75 × 100	PL7H	1	12,650		
	75 × 125	PL7Q	1	13,920		
	100 × 125	PLHQ	1	15,180		
	100 × 150	PLHF	1	17,710		
	125 × 125	PLQQ	1	15,180		※2
プラ脚部継手 通常グレード SUS仕様 	125 × 150	PLQF	1	17,710		※2
	75 × 100	PL7HS	1	15,180		※3
	75 × 125	PL7QS	1	16,450		※3
	100 × 125	PLHQS	1	17,710		※3
	100 × 150	PLHFS	1	20,240		※3
プラ脚部継手 ※1 遮音グレード 標準 	125 × 125	PLQQS	1	17,710		※2,3
	125 × 150	PLQFS	1	20,240		※2,3
	75 × 100	PLS7H	1	18,980		
	75 × 125	PLS7Q	1	20,240		
	100 × 125	PLSHQ	1	21,510		
プラ脚部継手 遮音グレード SUS仕様 	100 × 150	PLSHF	1	24,040		
	125 × 125	PLSQQ	1	21,510		※2,3
	125 × 150	PLSQF	1	24,040		※2,3
	75 × 100	PLS7HS	1	21,510		※3
	75 × 125	PLS7QS	1	22,770		※3
プラ脚部継手 遮音グレード SUS仕様 	100 × 125	PLSHQS	1	24,040		※3
	100 × 150	PLSHFS	1	26,570		※3
	125 × 125	PLSQQS	1	24,040		※2,3
	125 × 150	PLSQFS	1	26,570		※2,3

※1. 支持金具:ユニクロメッキ仕様です

※2. 呼び径125 × 125、125 × 150は耐火ブラAD継手HG 最下階タイプとの接続専用です

※3. 受注生産品です

(5)AD脚部継手

品名	サイズ	品番	梱包数	価格(円/個)	改定	備考	
AD脚部継手 (フランジ付品) 標準 	80 × 80	LEAD808	2	21,910			
	80 × 100	LEAD80	2	23,230			
	80 × 125	LEAD805	1	27,720			
	80 × 150	LEAD806	1	36,430			
	100 × 100	LEAD1H4	2	26,800			
	100 × 125	LEAD1H	1	33,920			
	100 × 150	LEAD1H6	1	39,200			
	100 × 200	LEAD1H8	1	59,140			
	AD脚部継手 (フランジ付品) SUS仕様 	80 × 80	LAD808S	2	26,270		
		80 × 100	LAD80S	2	27,590		
80 × 125		LAD805S	1	35,090			
80 × 150		LAD806S	1	43,800			
100 × 100		LAD1H4S	2	31,150			
100 × 125		LAD1HS	1	41,290			
100 × 150		LAD1H6S	1	46,570			
100 × 200		LAD1H8S	1	67,710			
ロングタイプ (フランジ付品) 標準 	80 × 100	LEAD84L	1	31,280			
	80 × 125	LEAD85L	1	32,870			
	80 × 150	LEAD86L	1	53,720			
	100 × 125	LEAD1HL	1	36,430			
	100 × 150	LEAD1FL	1	55,570			
	100 × 200	LEAD18L	1	71,540			
ロングタイプ (フランジ付品) SUS仕様 	80 × 100	LAD84LS	1	35,640			
	80 × 125	LAD85LS	1	40,240			
	80 × 150	LAD86LS	1	61,090			
	100 × 125	LAD1HLS	1	43,800			
	100 × 150	LAD1FLS	1	62,940			
	100 × 200	LAD18LS	1	80,110			
スリム直結ショートタイプ (フランジ、防振支持金具付品) 通常タイプ 標準 	80 × 100	LAD84RH	1	29,040			
	80 × 125	LAD85RH	1	38,540			
	100 × 125	LAD1HRH	1	39,730			
	100 × 150	LAD1FRH	1	45,010			
スリム直結ショートタイプ (フランジ、防振支持金具付品) 通常タイプ SUS仕様 	80 × 100	AD84RHS	1	40,660		※	
	80 × 125	AD85RHS	1	50,160		※	
	100 × 125	AD1HRHS	1	51,350		※	
	100 × 150	AD1FRHS	1	56,630		※	
スリム直結ショートタイプ (フランジ、防振支持金具付品) 掃除口付タイプ 標準 	80 × 100	LAD84RB	1	43,960			
	80 × 125	LAD85RB	1	49,630			
	100 × 125	LAD1HRB	1	52,010			
	100 × 150	LAD1FRB	1	63,360			
スリム直結ショートタイプ (フランジ、防振支持金具付品) 掃除口付タイプ SUS仕様 	80 × 100	AD84RBS	1	58,610		※	
	80 × 125	AD85RBS	1	64,280		※	
	100 × 125	AD1HRBS	1	66,660		※	
	100 × 150	AD1FRBS	1	78,010		※	
掃除口・ 支持付(フランジ付品) 標準 	80 × 100	LAD804B	1	43,960			
	100 × 125	LAD1H5B	1	52,140			
	100 × 150	LAD1H6B	1	63,230			
掃除口・ 支持付(フランジ付品) SUS仕様 	80 × 100	AD804BS	1	48,310			
	100 × 125	AD1H5BS	1	59,510			
	100 × 150	AD1H6BS	1	70,600			

※ SUS仕様:支持金具、フランジ用ボルト、ナット

(5)AD脚部継手

品名	対応 スラブ厚	サイズ	品番	梱包数	価格 (円/個)	改定	備考
防振タイプ (フランジ付品) 	235	80×100	LEAD84V	1	41,580		
	320	80×100	LEAD84X	1	46,600		
	235	80×125	LEAD85V	1	43,160		
	300	80×125	LEAD85X	1	48,180		
	235	80×150	LEAD86V	1	64,020		
	300	80×150	LEAD86X	1	69,040		
	235	100×125	LEAD1HV	1	48,050		
	305	100×125	LEAD1HX	1	53,060		
	235	100×150	LEAD1FV	1	67,190		
	295	100×150	LEAD1FX	1	72,200		
	235	100×200	LEAD18V	1	83,160		
	268	100×200	LEAD18X	1	87,250		

(6)耐火ブラAD継手HG・SG用 支持金具

品名	立て管サイズ	品番	梱包数	価格(円/個)	改定	備考
耐火ブラAD継手HG・ SG用支持金具 	75	SJKPAD	5	6,270		
	100					

(7)AD脚部継手 支持金具

品名	立て管サイズ	品番	梱包数	価格(円/個)	改定	備考
AD脚部継手用 支持金具 	80	SJKK80	20	4,880		
	100	SJKK100	20	5,020		
	125	SJKK125	15	6,600		
AD脚部継手用 支持金具(SUS製) 	80	SUSK80	20	10,820		
	100	SUSK100	20	11,350		
AD脚部継手 ロングタイプ用支持金具 	80	SJKL80	10	10,560		
	100	SJKL100	10	11,220		

(8)関連製品



品名	サイズ	品番	梱包数	価格(円/個)	改定	備考
掃除口付ソケット (COS) フランジタイプ 	80	COSM80	4	16,130		
	100	COSM1H	2	20,500		
	125	COSM1Q	1	35,090		
掃除口付ソケット (COS) RRタイプ 	80	COSRR80	4	16,730		
	100	COSRR1H	2	21,270		
	125	COSRR1Q	1	36,470		
満水試験兼用掃除口付 継手(COS-T II) フランジタイプ 	80	COSTM80	3	32,600		
	100	COSTM1H	2	45,470		
	125	COSTM1Q	1	66,920		
満水試験兼用掃除口付 継手(COS-T II) RRタイプ 	80	COSTR80	3	34,140		
	100	COSTR1H	2	47,100		
	125	COSTR1Q	1	69,500		
満水試験用治具 (COS-TPA II) 	80	ADMMA80	15	42,300		
	100	ADMMA1H	10	48,570		
	125	ADMMA1Q	5	60,740		

給排水用硬質ポリ塩化ビニル管・継手

1) 水道用硬質ポリ塩化ビニル管 [JIS K 6742/6741]

品名	サイズ	品番	梱包数	価格(円/本)	改定	備考	
HI/パイプ・ゴールド +(プラス) (JIS K 6742) 長さ:4m/本 	13	IW134	50	1,220			
	16	IW164	35	1,830			
	20	IW204	30	2,010			
	25	IW254	20	3,050			
	30	IW304	15	3,880			
	40	IW404	7	5,320			
	50	IW504	5	7,070			
	65	IP654	5	9,830			
	75	IW754	3	14,580			
	100	IW1H4	2	21,340			
	125	IP1Q4	2	29,190			
	150	IW1F4	1	44,290			
	長さ:5m/本	40	IW405	7	6,670		
		50	IW505	5	8,820		
		75	IW755	3	18,220		
		100	IW1H5	2	26,680		
		150	IW1F5	1	55,360		
HI/パイプ・ゴールド +(プラス) (JIS K 6741) 長さ:4m/本 	200	IP2H4	1	66,970			
	250	IP2F4	1	102,320			
	300	IP3H4	1	145,110			
パイプVPW (JIS K 6742) 長さ:4m/本 	13	VW134	50	990			
	16	VW164	35	1,450			
	20	VW204	30	1,680			
	25	VW254	20	2,380			
	30	VW304	15	3,030			
	40	VW404	7	4,310			
	50	VW504	5	5,850			
	長さ:5m/本	40	VW405	7	5,370		
		50	VW505	5	7,350		
		75	VW755	3	13,950		
		100	VW1H5	2	20,570		
		150	VW1F5	1	41,830		

2) 一般用硬質ポリ塩化ビニル管 [JIS K 6741]

品名	サイズ	品番	梱包数	価格(円/本)	改定	備考
VP (JIS K 6741) 長さ:4m/本 	40	VP404	7	3,430		
	50	VP504	5	4,840		
	65	VP654	5	6,170		
	75	VP754	3	9,470		
	100	VP1H4	2	13,920		
	125	VP1Q4	2	17,860		
	150	VP1F4	1	26,810		
	200	VP2H4	1	40,210		
	250	VP2F4	1	62,380		
	300	VP3H4	1	88,200		
VU (JIS K 6741) 長さ:4m/本 	40	VU404	20	1,840		
	50	VU504	15	2,290		
	65	VU654	10	3,510		
	75	VU754	7	4,650		
	100	VU1H4	5	6,990		
	125	VU1Q4	3	11,300		
	150	VU1F4	1	16,250		
	200	VU2H4	1	26,820		
	250	VU2F4	1	40,210		
	300	VU3H4	1	56,580		
	350	VU3F4	1	76,260		
400	VU4H4	1	101,310			
450	VU4F4	1	128,120			
500	VU5H4	1	160,920			
600	VU6H4	1	243,130			

3) エスロン発泡三層パイプ



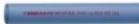

(建物用リサイクル硬質ポリ塩化ビニル発泡三層管)[JIS K 9798]

品名	サイズ	品番	梱包数	価格(円/本)	改定	備考
RF-VP (JIS K 9798) 灰青色 (標準色) 長さ:4m/本 	40	RFP404N	7	3,590		
	50	RFP504N	5	5,060		
	65	RFP654N	4	6,450		
	75	RFP754N	3	9,900		
	100	RFP1H4N	2	14,550		
	125	RFP1Q4N	1	18,680		
	150	RFP1F4N	1	28,030		

4) エスロン三層パイプ(リサイクル硬質ポリ塩化ビニル三層管) [JIS K 9797]

品名	サイズ	品番	梱包数	価格(円/本)	改定	備考
RS-VU (JIS K 9797) 長さ:4m/本 	100	RSVU1H4	5	7,300		
	150	RSVU1F4	1	16,990		
	200	RSVU2H4	1	28,040		

5) エスロンカラーパイプ(排水用硬質ポリ塩化ビニル管) [JIS K 6741]

品名	サイズ	品番	梱包数	価格(円/本)	改定	備考	
カラーパイプVP シルバー 長さ:4m/本 	40	VPC404L	7	5,390	☆	※	
	50	VPC504L	5	7,520	☆	※	
	65	VPC654L	5	9,610	☆	※	
	75	VPC754L	3	14,770	☆	※	
	100	VPC1H4L	2	22,010	☆	※	
	125	VPC1Q4L	2	27,970	☆	※	
	150	VPC1F4L	1	42,250	☆	※	
	長さ:3m/本	75	VPC753L	3	11,410	☆	※
		100	VPC1H3L	2	17,100	☆	※
	カラーパイプVP ホワイト 長さ:4m/本 	50	VPC504W	5	7,520	☆	※
65		VPC654W	5	9,610	☆	※	
75		VPC754W	3	14,770	☆	※	
100		VPC1H4W	2	22,010	☆	※	
125		VPC1Q4W	2	27,970	☆	※	
150		VPC1F4W	1	42,250	☆	※	
長さ:3m/本		75	VPC753W	3	11,410	☆	※
		100	VPC1H3W	2	17,100	☆	※
カラーパイプVP ココア 長さ:4m/本 		50	VPC504E	5	7,520	☆	※
		65	VPC654E	5	9,610	☆	※
	75	VPC754E	3	14,770	☆	※	
	100	VPC1H4E	2	22,010	☆	※	
	125	VPC1Q4E	2	27,970	☆	※	
	長さ:3m/本	75	VPC753E	3	11,410	☆	※
		100	VPC1H3E	2	17,100	☆	※
	カラーパイプVP クリーム 長さ:4m/本 	50	VPC504C	5	7,520	☆	※
		65	VPC654C	5	9,610	☆	※
		75	VPC754C	3	14,770	☆	※
100		VPC1H4C	2	22,010	☆	※	
125		VPC1Q4C	2	27,970	☆	※	
150		VPC1F4C	1	42,250	☆	※	
長さ:3m/本		75	VPC753C	3	11,410	☆	※
		100	VPC1H3C	2	17,100	☆	※

※ マンセルNo.

シルバー : 5. 6Y 6. 8/1. 2

ホワイト : 4. 3Y 8. 4/0. 8

ココア : 3. 9YR 4. 8/1. 5

クリーム : 2. 9Y 7. 4/2. 4

タフグレー : N4

5) エスロンカラーパイプ (排水用硬質ポリ塩化ビニル管) [JIS K 6741]

品名	サイズ	品番	梱包数	価格(円/本)	改定	備考
カラーパイプVP タフグレー						
長さ:4m/本	50	VP504TG	5	7,520	☆	※
	65	VP654TG	5	9,610	☆	※
	75	VP754TG	3	14,770	☆	※
	100	VP1H4TG	2	22,010	☆	※
	125	VP1Q4TG	2	27,970	☆	※
	150	VP1F4TG	1	42,250	☆	※
長さ:3m/本	75	VP753TG	3	11,410	☆	※
	100	VP1H3TG	2	17,100	☆	※
カラーパイプVU シルバー						
長さ:4m/本	50	VUC504L	15	3,660	☆	※
	65	VUC654L	10	5,710	☆	※
	75	VUC754L	7	7,520	☆	※
	100	VUC1H4L	5	11,120	☆	※
	125	VUC1Q4L	3	17,620	☆	※
	150	VUC1F4L	2	25,630	☆	※
長さ:3m/本	75	VUC753L	7	5,710	☆	※
	100	VUC1H3L	5	8,300	☆	※
カラーパイプVU ホワイト						
長さ:4m/本	50	VUC504W	15	3,660	☆	※
	65	VUC654W	10	5,710	☆	※
	75	VUC754W	7	7,520	☆	※
	100	VUC1H4W	5	11,120	☆	※
	125	VUC1Q4W	3	17,620	☆	※
	150	VUC1F4W	2	25,630	☆	※
長さ:3m/本	75	VUC753W	7	5,710	☆	※
	100	VUC1H3W	5	8,300	☆	※
カラーパイプVU ココア						
長さ:4m/本	50	VUC504E	15	3,660	☆	※
	65	VUC654E	10	5,710	☆	※
	75	VUC754E	7	7,520	☆	※
	100	VUC1H4E	5	11,120	☆	※
	125	VUC1Q4E	3	17,620	☆	※
	150	VUC1F4E	2	25,630	☆	※
長さ:3m/本	75	VUC753E	7	5,710	☆	※
	100	VUC1H3E	5	8,300	☆	※
カラーパイプVU クリーム						
長さ:4m/本	50	VUC504C	15	3,660	☆	※
	65	VUC654C	10	5,710	☆	※
	75	VUC754C	7	7,520	☆	※
	100	VUC1H4C	5	11,120	☆	※
	125	VUC1Q4C	3	17,620	☆	※
	150	VUC1F4C	2	25,630	☆	※
長さ:3m/本	75	VUC753C	7	5,710	☆	※
	100	VUC1H3C	5	8,300	☆	※
カラーパイプVU タフグレー						
長さ:4m/本	50	VU504TG	15	3,660	☆	※
	65	VU654TG	10	5,710	☆	※
	75	VU754TG	7	7,520	☆	※
	100	VU1H4TG	5	11,120	☆	※
	125	VU1Q4TG	3	17,620	☆	※
	150	VU1F4TG	2	25,630	☆	※
長さ:3m/本	75	VU753TG	7	5,710	☆	※
	100	VU1H3TG	5	8,300	☆	※

※ マンセルNo.

シルバー : 5. 6Y 6. 8 / 1. 2

ホワイト : 4. 3Y 8. 4 / 0. 8

ココア : 3. 9YR 4. 8 / 1. 5

クリーム : 2. 9Y 7. 4 / 2. 4

タフグレー : N4





6) エスロンHITS継手・ゴールド

(水道用耐衝撃性硬質ポリ塩化ビニル管継手) [JIS K 6743]

品名	サイズ	品番	梱包数	価格(円/個)	改定	備考
ソケット(HI-S・G)	13	HIS13	210	101		
	16	HIS16	130	121		
	20	HIS20	85	138		
	25	HIS25	50	209		
	30	HIS30	35	271		
	40	HIS40	40	456		
	50	HIS50	24	693		
	65	HIS65	30	1,185		
	75	HIS75	22	1,749		
	100	HIS1H	10	3,551		
	125	HIS1Q	8	6,250		
	150	HIS1F	4	8,775		
	チーズ(HI-T・G)	13	HIT13	110	110	
16		HIT16	60	191		
20		HIT20	40	259		
25		HIT25	20	391		
30		HIT30	15	543		
40		HIT40	15	904		
50		HIT50	10	1,455		
65		HIT65	14	2,648		
75		HIT75	10	4,317		
100		HIT1H	4	8,901		
125		HIT1Q	3	14,671		
150		HIT1F	2	27,961		
エルボ(HI-L・G)		13	HIL13	170	101	
	16	HIL16	100	137		
	20	HIL20	60	166		
	25	HIL25	35	262		
	30	HIL30	25	349		
	40	HIL40	30	607		
	50	HIL50	15	940		
	65	HIL65	20	1,830		
	75	HIL75	15	2,708		
	100	HIL1H	7	5,332		
	125	HIL1Q	5	10,147		
	150	HIL1F	3	17,402		
	径違いソケット (HI-R・G)	16×13	HIS161	160	126	
20×13		HIS202	120	139		
20×16		HIS201	100	139		
25×13		HIS253	70	209		
25×16		HIS252	65	209		
25×20		HIS251	60	209		
30×13		HIS304	50	266		
30×20		HIS302	40	266		
30×25		HIS301	40	266		
40×20		HIS404	50	464		
40×25		HIS403	50	464		
40×30		HIS402	45	464		
50×20		HIS505	30	713		
50×25		HIS504	25	713		
50×30		HIS503	25	713		
50×40		HIS501	25	713		
65×50		HIS651	40	1,233		
75×50		HIS752	30	1,749		
75×65		HIS751	30	1,749		
100×75		HIS1H1	15	3,551		
125×100	HIS1Q1	12	6,350			
150×100	HIS1F2	4	10,460			
150×125	HIS1F1	4	10,460			

6) エスロンHITS継手・ゴールド

(水道用耐衝撃性硬質ポリ塩化ビニル管継手) [JIS K 6743]

品名	サイズ	品番	梱包数	価格(円/個)	改定	備考
径違いチーズ (HI-RT・G) 	16×13	HIT161	80	191		
	20×13	HIT202	50	249		
	20×16	HIT201	50	249		
	25×13	HIT253	35	381		
	25×16	HIT252	30	381		
	25×20	HIT251	25	381		
	30×13	HIT304	25	530		
	30×16	HIT303	20	530		
	30×20	HIT302	20	530		
	30×25	HIT301	18	530		
	40×13	HIT406	30	871		
	40×16	HIT405	28	871		
	40×20	HIT404	25	871		
	40×25	HIT403	23	871		
	40×30	HIT402	23	871		
	50×13	HIT507	20	1,392		
	50×16	HIT506	17	1,392		
	50×20	HIT505	17	1,392		
	50×25	HIT504	15	1,392		
	50×30	HIT503	13	1,392		
	50×40	HIT501	11	1,392		
	65×50	HIT651	18	2,552		
	75×25	HIT755	18	3,525		
	75×40	HIT753	14	3,525		
	75×50	HIT752	12	3,525		
	75×65	HIT751	10	3,525		
	100×50	HIT1H3	6	7,418		
100×75	HIT1H1	5	7,418			
125×100	HIT1Q1	3	14,119			
150×75	HIT1F3	2	26,712			
150×100	HIT1F2	2	26,712			
150×125	HIT1F1	2	26,712			
径違いエルボ (HI-RL・G) 	20×13	HIL202	100	229		※
	25×13	HIL253	75	430		※
	25×20	HIL251	50	430		※
45°エルボ (HI-45L・G) 	13	HI4L13	180	125		
	20	HI4L20	65	259		
	25	HI4L25	40	439		
	30	HI4L30	25	586		
	40	HI4L40	30	1,100		
	50	HI4L50	15	1,583		
	65	HI4L65	24	3,208		
	75	HI4L75	12	4,342		
	100	HI4L1H	6	5,019		
	125	HI4L1Q	6	16,222		
150	HI4L1F	2	24,132			
キャップ (HI-C・G) 	13	HIC13X	370	108		
	16	HIC16X	240	123		
	20	HIC20X	160	123		
	25	HIC25X	80	169		
	30	HIC30X	55	186		
	40	HIC40X	60	360		
	50	HIC50X	35	554		
	75	HIC75	36	1,931		
ユニオンソケット (HI-US・G) 	13	HIUS13N	225	98		
	16	HIUS16N	150	125		
	20	HIUS20N	100	130		
	25	HIUS25	60	200		
	30	HIUS30	40	278		
	40	HIUS40	50	407		
	50	HIUS50	25	625		

※ メーカー規格品です

品名	サイズ	品番	梱包数	価格(円/個)	改定	備考
パルプソケット (HI-VS・G) 	13×R1/2	HIVS13N	250	104		
	16×R1/2	HIVS16N	180	126		
	20×R3/4	HIVS20N	110	127		
	25×R1	HIVS25	60	202		
	30×R1 1/4	HIVS30	40	259		
	40×R1 1/2	HIVS40	50	374		
	50×R2	HIVS50	30	563		
	65×R2 1/2	HIVS65	60	901		※
	75×R3	HIVS75	36	1,284		※
	100×R4	HIVS1H	18	2,396		※
給水栓用エルボ (HI-SL・G) 	13×Rp1/2	HIWL13	150	130		※
	16×Rp1/2	HIWL16	110	199		※
	20×Rp3/4	HIWL20	70	273		※
	25×Rp1	HIWL25	40	425		※
給水栓用ソケット (HI-SS・G) 	13×Rp1/2	HIWS13	200	117		※
	16×Rp1/2	HIWS16	150	147		※
	20×Rp3/4	HIWS20	90	199		※
	25×Rp1	HIWS25	50	282		※
給水栓用チーズ (HI-ST・G) 	13×Rp1/2	HIWT13	100	217		※
	20×Rp1/2	HIWT202	50	328		※
	20×Rp3/4	HIWT20	40	448		※
	25×Rp1	HIWT25	20	730		※

※ メーカー規格品です

7) エスロン金属入りHI給水栓継手・ゴールド [JIS K 6743]

品名	サイズ	品番	梱包数	価格(円/個)	改定	備考
給水栓用エルボ(S形) (インサート付) (HI-ISL・G) 	13×Rp1/2	IIWL13M	150	1,040		☆
	16×Rp1/2	IIWL16M	100	1,330		☆
	20×Rp1/2	IIWL22M	80	1,550		☆
	20×Rp3/4	IIWL20M	60	1,700		☆
	25×Rp1	IIWL25M	35	2,660		☆
給水栓用エルボ(L形) (インサート付) (HI-LL・G) 	13×Rp1/2	IIL13LM	100	1,250		☆
	16×Rp1/2	IIL16LM	80	1,390		☆
	20×Rp1/2	IIL20LM	70	1,610		☆
給水栓用座付エルボ (インサート付) (HI-IZL・G) 	13×Rp1/2	IIZL13M	85	1,760		☆ ※
	20×Rp1/2	IIZL22M	55	1,940		☆ ※
給水栓用座付きエルボ (インサートなし) (HI-ZL・G) 	13×Rp1/2	HIZWL13	110	191		※
天座付給水栓用エルボ (インサート付) (HI-TZL・G) 	13×Rp1/2	IITZL1M	85	1,760		☆ ※
	20×Rp1/2	IITZL2M	50	1,940		☆ ※
給水栓用チーズ (インサート付) (HI-IST・G) 	13×Rp1/2	IIWT13M	100	1,250		☆
	16×Rp1/2	IIWT11M	60	1,700		☆
	20×Rp1/2	IIWT22M	50	2,040		☆
	20×Rp3/4	IIWT20M	40	2,400		☆
	25×Rp1/2	IIWT23M	35	2,840		☆
給水栓用ソケット (インサート付) (HI-ISS・G) 	25×Rp1	IIWT25M	20	3,920		☆
	13×Rp1/2	IIWS13M	170	890		☆
	16×Rp1/2	IIWS16M	130	1,140		☆
	20×Rp1/2	IIWS22M	100	1,450		☆
	20×Rp3/4	IIWS20M	90	1,550		☆
25×Rp1	IIWS25M	45	2,530		☆	



※ メーカー規格品です

7) エスロン金属入りHI給水栓継手・ゴールド [JIS K 6743]





品名	サイズ	品番	梱包数	価格(円/個)	改定	備考
めすおすエルボ (インサート付) (HI-IMOL・G) 	20×Rp3/4	IIL20AM	45	1,860	☆	※
バルブソケット I 型 (インサート付) (HI-IVS・G) 	13×R1/2	IIVS13M	130	1,780	☆	
	16×R1/2	IIVS16M	100	2,010	☆	
	20×R3/4	IIVS20M	65	2,580	☆	
	25×R1	IIVS25M	35	3,810	☆	
	30×R1 1/4	IIVS30M	36	4,820	☆	
	40×R1 1/2	IIVS40M	20	5,820	☆	
バルブソケット II 型 (インサート付) (HI-KVS・G) 	13×R1/2	IKVS13	100	2,140	☆	
	16×R1/2	IKVS16	80	2,500	☆	
	20×R3/4	IKVS20	48	3,080	☆	
	25×R1	IKVS25	32	4,540	☆	
	30×R1 1/4	IKVS30	28	5,770	☆	
	40×R1 1/2	IKVS40	20	6,960	☆	
	50×R2	IKVS50	10	9,030	☆	

※ メーカー規格品です

8) エスロンTS継手(水道用硬質ポリ塩化ビニル管継手) [JIS K 6743]

品名	サイズ	品番	梱包数	価格(円/個)	改定	備考
径違いソケット(R) 	16×13	TSS161	160	90		
	20×13	TSS202	120	98		
	20×16	TSS201	100	98		
	25×13	TSS253	70	147		
	25×16	TSS252	65	147		
	25×20	TSS251	60	147		
	30×13	TSS304	50	194		
	30×20	TSS302	40	194		
	30×25	TSS301	40	194		
	40×20	TSS404	50	331		
	40×25	TSS403	50	331		
	40×30	TSS402	45	331		
	50×20	TSS505	30	490		
	50×25	TSS504	25	490		
	50×30	TSS503	25	490		
	50×40	TSS501	25	490		
	65×50	TSS651	40	909		
	75×50	TSS752	30	1,268		
	75×65	TSS751	30	1,268		
	100×75	TSS1H1	15	2,379		
125×100	TSS1Q1	12	4,396			
150×100	TSS1F2	4	7,558			
150×125	TSS1F1	4	7,558			
径違いエルボ(RL) 	20×13	TSL202	100	153		※
	25×13	TSL253	75	215		※
	25×20	TSL251	50	288		※
キャップ(C) 	13	TSC13X	370	75		
	16	TSC16X	240	88		
	20	TSC20X	160	89		
	25	TSC25X	80	114		
	30	TSC30X	55	147		
	40	TSC40X	60	249		
	50	TSC50X	35	413		
	75	TSC75	36	1,374		
	100	TSC1H	18	2,460		
	150	TSC1F	6	6,264		

※ メーカー規格品です

品名	サイズ	品番	梱包数	価格(円/個)	改定	備考
径違いチーズ(RT) 	16×13	TST161	80	147		
	20×13	TST202	50	180		
	20×16	TST201	50	180		
	25×13	TST253	35	280		
	25×16	TST252	30	280		
	25×20	TST251	25	280		
	30×13	TST304	25	377		
	30×16	TST303	20	377		
	30×20	TST302	20	377		
	30×25	TST301	18	377		
	40×13	TST406	30	530		
	40×16	TST405	28	530		
	40×20	TST404	25	530		
	40×25	TST403	23	530		
	40×30	TST402	23	530		
	50×13	TST507	20	852		
	50×16	TST506	17	852		
	50×20	TST505	17	852		
	50×25	TST504	15	852		
	50×30	TST503	13	852		
	50×40	TST501	11	852		
	65×50	TST651	18	1,741		
	75×25	TST756	18	2,966		
75×40	TST753	14	2,966			
75×50	TST752	12	2,966			
75×65	TST751	10	2,966			
100×50	TST1H3	6	5,879			
100×75	TST1H1	5	5,879			
125×100	TST1Q1	3	10,063			
150×75	TST1F3	2	17,914			
150×100	TST1F2	2	17,914			
150×125	TST1F1	2	17,914			
ユニオンソケット(US) 	13	TSUS13N	225	81		
	16	TSUS16N	150	105		
	20	TSUS20N	100	109		
	25	TSUS25	60	173		
	30	TSUS30	40	231		
	40	TSUS40	50	338		
	50	TSUS50	25	532		
ソケット(S) 	13	TSS13	210	76		
	16	TSS16	130	88		
	20	TSS20	85	100		
	25	TSS25	50	153		
	30	TSS30	35	205		
	40	TSS40	40	342		
	50	TSS50	24	499		
	65	TSS65	30	876		
	75	TSS75	22	1,271		
	100	TSS1H	10	2,574		
	125	TSS1Q	8	4,485		
	150	TSS1F	4	7,456		
	チーズ(T) 	13	TST13	110	95	
16		TST16	60	147		
20		TST20	40	181		
25		TST25	20	280		
30		TST30	15	370		
40		TST40	15	619		
50		TST50	10	1,036		
65		TST65	14	1,947		
75		TST75	10	2,966		
100		TST1H	4	6,127		
125		TST1Q	3	10,531		
150		TST1F	2	19,885		

8) エスロンTS継手 (水道用硬質ポリ塩化ビニル管継手) [JIS K 6743]

品名	サイズ	品番	梱包数	価格(円/個)	改定	備考
エルボ(L) 	13	TSL13	170	75		
	16	TSL16	100	95		
	20	TSL20	60	127		
	25	TSL25	35	188		
	30	TSL30	25	252		
	40	TSL40	30	441		
	50	TSL50	15	709		
	65	TSL65	20	1,357		
	75	TSL75	15	1,940		
	100	TSL1H	7	3,817		
	125	TSL1Q	5	7,444		
150	TSL1F	3	12,452			
45°エルボ(45L) 	13	TS4L13	180	111		
	20	TS4L20	65	212		
	25	TS4L25	40	313		
	30	TS4L30	25	419		
	40	TS4L40	30	734		
	50	TS4L50	15	1,133		
	65	TS4L65	24	2,387		
	75	TS4L75	12	3,102		
	100	TS4L1H	6	3,674		
	125	TS4L1Q	6	11,587		
150	TS4L1F	2	17,241			
給水栓用エルボ(SL) 	13×Rp1/2	TSWL13	150	108	※	
	16×Rp1/2	TSWL16	110	147	※	
	20×Rp3/4	TSWL20	70	175	※	
	25×Rp1	TSWL25	40	242	※	
給水栓用ソケット(SS) 	13×Rp1/2	TSWS13	200	108	※	
	16×Rp1/2	TSWS16	150	113	※	
	20×Rp3/4	TSWS20	90	113	※	
	25×Rp1	TSWS25	50	190	※	
給水栓用チーズ(ST) 	13×Rp1/2	TSWT13	100	156	※	
	16×Rp1/2	TSWT161	65	205	※	
	20×Rp1/2	TSWT202	50	328	※	
	20×Rp3/4	TSWT20	40	316	※	
	25×Rp1	TSWT25	20	482	※	
バルブ用ソケット(VS) 	13×R1/2	TSVS13N	250	80		
	16×R1/2	TSVS16N	180	89		
	20×R3/4	TSVS20N	110	90		
	25×R1	TSVS25	60	127		
	30×R1 1/4	TSVS30	40	205		
	40×R1 1/2	TSVS40	50	252		
	50×R2	TSVS50	30	394		
	65×R2 1/2	TSVS65	60	631	※	
	75×R3	TSVS75	36	881	※	
100×R4	TSVS1H	18	1,658	※		
シンプルジョイント(SJ) 	13	SMJ13	65	450		
	20	SMJ20	32	700		
	25	SMJ25	25	870		
	30	SMJ30	18	1,280		
	40	SMJ40	20	1,690		
	50	SMJ50	12	1,830		





※ メーカー規格品です

9) エスロン金属入り給水栓継手 (水道用硬質ポリ塩化ビニル管インサート付継手) [JIS K 6743]

品名	サイズ	品番	梱包数	価格(円/個)	改定	備考
給水栓用エルボ(S形) (インサート付) (ISL) 	13×Rp1/2	IWL13M	150	770	☆	
	16×Rp1/2	IWL16M	100	840	☆	
	20×Rp1/2	IWL202M	80	1,200	☆	
	20×Rp3/4	IWL20M	60	1,200	☆	
	25×Rp1	IWL25M	35	1,990	☆	
給水栓用エルボ(L形) (インサート付) (LL) 	13×Rp1/2	IWL13LM	100	890	☆	
	16×Rp1/2	IWL16LM	80	990	☆	
	20×Rp1/2	IWL20LM	70	1,130	☆	
給水栓用座付きエルボ (インサート付) (IZL) 	13×Rp1/2	IZL13M	85	1,330	☆	※
	20×Rp1/2	IZL22M	55	1,480	☆	※
給水栓用座付きエルボ (インサートなし) (ZL) 	13×Rp1/2	TSZWL13	110	160	☆	※
天座付給水栓用 エルボ(インサート付) (TZL) 	13×Rp1/2	ITZL13M	85	1,330	☆	※
	20×Rp1/2	ITZL20M	50	1,480	☆	※
給水栓用ソケット (インサート付) (ISS) 	13×Rp1/2	IWS13M	170	680	☆	
	16×Rp1/2	IWS16M	130	700	☆	
	20×Rp1/2	IWS202M	100	1,130	☆	
	20×Rp3/4	IWS20M	90	1,130	☆	
	25×Rp1	IWS25M	45	1,850	☆	
給水栓用チーズ (インサート付) (IST) 	13×Rp1/2	IWT13M	100	810	☆	
	16×Rp1/2	IWT161M	60	1,200	☆	
	20×Rp1/2	IWT202M	50	1,270	☆	
	20×Rp3/4	IWT20M	40	1,470	☆	
	25×Rp1/2	IWT253M	35	1,900	☆	
	25×Rp3/4	IWT252M	30	2,320	☆	
25×Rp1	IWT25M	20	2,320	☆		
バルブソケット I 型 (インサート付) (IVS) 	13×R1/2	IVS13M	130	1,180	☆	
	16×R1/2	IVS16M	100	1,210	☆	
	20×R3/4	IVS20M	65	1,710	☆	
	25×R1	IVS25M	35	2,600	☆	
	30×R1 1/4	IVS30M	36	3,590	☆	
	40×R1 1/2	IVS40M	20	4,350	☆	
	50×R2	IVS50M	12	5,610	☆	
バルブソケット II 型 (インサート付) (KVS) 	13×R1/2	TKVS13	100	1,440	☆	
	16×R1/2	TKVS16	80	1,600	☆	
	20×R3/4	TKVS20	48	2,070	☆	
	25×R1	TKVS25	32	3,090	☆	
	30×R1 1/4	TKVS30	28	4,300	☆	
	40×R1 1/2	TKVS40	20	5,230	☆	
50×R2	TKVS50	10	6,740	☆		

※ メーカー規格品です

10) エスロンHI継手透明ブルー (水道用耐衝撃性硬質ポリ塩化ビニル管継手)

品名	サイズ	品番	梱包数	価格(円/個)	改定	備考	
ソケット 	13	EHIS13	210	116			
	16	EHIS16	130	139			
	20	EHIS20	85	159			
	25	EHIS25	50	239			
	30	EHIS30	35	313			
	40	EHIS40	40	526			
	50	EHIS50	24	797			
	16×13	EHIS161	160	143			
	20×13	EHIS202	120	160			
	20×16	EHIS201	100	160			
	25×13	EHIS253	70	239			
	25×16	EHIS252	65	239			
	25×20	EHIS251	60	239			
	30×13	EHIS304	50	304			
	30×20	EHIS302	40	304			
	30×25	EHIS301	40	304			
	40×20	EHIS404	50	533			
	40×25	EHIS403	50	533			
40×30	EHIS402	45	533				
50×25	EHIS504	25	818				
50×30	EHIS503	25	818				
50×40	EHIS501	25	818				
チーズ 	13	EHIT13	110	127			
	16	EHIT16	60	220			
	20	EHIT20	40	297			
	25	EHIT25	20	452			
	30	EHIT30	15	624			
	40	EHIT40	15	1,040			
	50	EHIT50	10	1,672			
	16×13	EHIT161	80	220			
	20×13	EHIT202	50	288			
	20×16	EHIT201	50	288			
	25×13	EHIT253	35	440			
	25×16	EHIT252	30	440			
	25×20	EHIT251	25	440			
	30×13	EHIT304	25	607			
	30×16	EHIT303	20	607			
	30×20	EHIT302	20	607			
	30×25	EHIT301	18	607			
	40×13	EHIT406	30	1,003			
	40×16	EHIT405	28	1,003			
	40×20	EHIT404	25	1,003			
	40×25	EHIT403	23	1,003			
	40×30	EHIT402	23	1,003			
	50×13	EHIT507	20	1,598			
	50×16	EHIT506	17	1,598			
	50×20	EHIT505	17	1,598			
	50×25	EHIT504	15	1,598			
	50×30	EHIT503	13	1,598			
	50×40	EHIT501	11	1,598			
エルボ 	13	EHIL13	170	116			
	16	EHIL16	100	156			
	20	EHIL20	60	190			
	25	EHIL25	35	301			
	30	EHIL30	25	401			
	40	EHIL40	30	700			
	50	EHIL50	15	1,081			
	20×13	EHIL202	100	263			
	キャップ 	13	EHIC13N	300	125		
		16	EHIC16N	200	140		
20		EHIC20N	120	140			
25		EHIC25	80	196			
30		EHIC30	60	212			
40		EHIC40	65	413			
50		EHIC50	35	638			

品名	サイズ	品番	梱包数	価格(円/個)	改定	備考
45°エルボ 	13	EHI4L13	180	141		
	20	EHI4L20	65	297		
	25	EHI4L25	40	502		
	30	EHI4L30	25	675		
	40	EHI4L40	30	1,264		
	50	EHI4L50	15	1,820		

11) エスロンHI継手透明ブルー (インサート付)

品名	サイズ	品番	梱包数	価格(円/個)	改定	備考
水栓エルボ (インサート付) 	13×Rp1/2	EHWL13M	150	1,200	☆	
	16×Rp1/2	EHWL16M	100	1,530	☆	
	20×Rp1/2	EHWL22M	80	1,770	☆	
	20×Rp3/4	EHWL20M	60	1,980	☆	
	25×Rp1	EHWL25M	35	3,080	☆	
水栓ソケット (インサート付) 	13×Rp1/2	EHWS13M	170	1,040	☆	
	16×Rp1/2	EHWS16M	130	1,300	☆	
	20×Rp1/2	EHWS22M	100	1,770	☆	
	20×Rp3/4	EHWS20M	90	1,770	☆	
	25×Rp1	EHWS25M	45	2,910	☆	
座付水栓エルボ (インサート付) 	13×Rp1/2	EHZL13M	85	2,020	☆	
	20×Rp1/2	EHZL22M	55	2,230	☆	
天座付水栓エルボ (インサート付) 	13×Rp1/2	EHTZL1M	85	2,020	☆	
	20×Rp1/2	EHTZL2M	50	2,230	☆	
バルブソケット (インサート付) 	13×R1/2	EHVS13M	130	2,040	☆	
	16×R1/2	EHVS16M	100	2,300	☆	
	20×R3/4	EHVS20M	65	2,960	☆	
	25×R1	EHVS25M	35	4,390	☆	
	30×R1 1/4	EHVS30M	36	5,540	☆	
	40×R1 1/2	EHVS40M	20	6,690	☆	
	50×R2	EHVS50M	12	8,670	☆	

水道用耐衝撃性硬質ポリ塩化ビニル管継手 エスロン®HI継手透明ブルー

HIパイプ・ゴールドが誇る接着強度を、より確実に実現。

これまでにない接着強度を誇る、「エスロンHIパイプ・ゴールド+ (プラス)」。積水化学ではこの接着強度をより確実に実現するため、接合状況が目視で確認できる、「エスロンHI継手透明ブルー」を開発。接着剤NO.83Sホワイト、NO.20Sホワイトと合わせ三位一体で、確実に強いジョイントを実現します。





HT継手透明ブルーには……







接合状態を目視で確認！



12) エスロンDV継手(排水用硬質ポリ塩化ビニル管継手)[JIS K 6739]

品名	サイズ	品番	梱包数	価格(円/個)	改定	備考
90°エルボ (DL) 	30	DDL30	300	123		
	40	DDL40	150	158		
	50	DDL50	85	257		
	65	DDL65	36	443		
	75	DDL75	30	606		
	100	DDL1H	16	1,211		
	125	DDL1Q	8	2,563		
	150	DDL1F	5	4,396		
45°エルボ (45L) 	30	D4L30	340	123		
	40	D4L40	190	153		
	50	D4L50	100	232		
	65	D4L65	46	382		
	75	D4L75	40	526		
	100	D4L1H	20	1,022		
	125	D4L1Q	10	2,176		
	150	D4L1F	6	3,572		
ソケット (DS) 	30	DDS30	540	102		
	40	DDS40	280	112		
	50	DDS50	160	151		
	65	DDS65	74	233		
	75	DDS75	70	376		
	100	DDS1H	34	718		
	125	DDS1Q	14	1,423		
150	DDS1F	12	2,439			
インクリーザー (IN) 	40×30	DIN402	270	131		
	50×40	DIN501	150	153		
	65×40	DIN652	130	295		
	65×50	DIN651	100	295		
	75×40	DIN753	120	420		
	75×50	DIN752	120	420		
	75×65	DIN751	90	420		
	100×40	DIN1H4	54	589		
	100×50	DIN1H3	54	589		
	100×65	DIN1H2	54	616		
	100×75	DIN1H1	48	677		
	125×75	DIN1Q2	28	959		
	125×100	DIN1Q1	25	984		
	150×100	DIN1F2	20	1,536		
	150×125	DIN1F1	18	1,961		
90°Y (DT) 	30	DDT30	180	170		
	40	DDT40	100	245		
	50	DDT50	50	392		
	65	DDT65	24	646		
	75	DDT75	24	881		
	100	DDT1H	12	1,820		
	125	DDT1Q	6	3,339		
	150	DDT1F	4	6,003		
	40×30	DDT402	120	202		
	50×30	DDT503	76	281		
	50×40	DDT501	66	281		
	65×40	DDT652	40	510		
	65×50	DDT651	34	510		
	75×40	DDT753	34	712		
	75×50	DDT752	34	712		
	75×65	DDT751	30	712		
	100×40	DDT1H4	24	1,373		
	100×50	DDT1H3	22	1,373		
	100×65	DDT1H2	16	1,373		
	100×75	DDT1H1	14	1,373		
	125×75	DDT1Q2	8	3,019		
	125×100	DDT1Q1	8	3,019		
	150×75	DDT1F3	7	5,724		
	150×100	DDT1F2	6	5,724		
	150×125	DDT1F1	5	5,724		

品名	サイズ	品番	梱包数	価格(円/個)	改定	備考
90°大曲りY (LT) 	40	DLT40	70	411		
	50	DLT50	34	540		
	65	DLT65Y	16	948		
	75	DLT75	16	1,362		
	100	DLT1H	8	2,638		
	125	DLT1Q	4	4,392		
	150	DLT1F	3	9,137		
	50×40	DLT501	46	484		
	65×40	DLT652	30	712		
	65×50	DLT651Y	22	712		
	75×40	DLT753	30	1,017		
	75×50	DLT752	26	1,017		
	75×65	DLT751	20	1,017		
	100×40	DLT1H4	18	1,958		
	100×50	DLT1H3	14	1,958		
	100×65	DLT1H2	12	1,958		
	100×75	DLT1H1	12	1,958		
	125×50	DLT1Q4	6	4,116		
	125×65	DLT1Q3	6	4,116		
	125×75	DLT1Q2	6	4,116		
	125×100	DLT1Q1	4	4,116		
150×65	DLT1F4	5	6,807			
150×75	DLT1F3	5	6,807			
150×100	DLT1F2	4	6,807			
150×125	DLT1F1	3	6,807			
45°Y (Y) 	40	DY40	70	347		
	50	DY50	40	500		
	65	DY65Y	18	819		
	75	DY75	16	1,196		
	100	DY1H	8	2,467		
	125	DY1Q	4	4,583		
	150	DY1F	3	10,366		
	40×30	DY402	100	245		
	50×30	DY503	70	357		
	50×40	DY501	50	357		
	65×40	DY652	30	661		
	65×50	DY651Y	24	661		
	75×40	DY753	32	864		
	75×50	DY752	26	864		
	75×65	DY751	20	864		
	100×40	DY1H4	22	1,780		
	100×50	DY1H3	16	1,780		
	100×65	DY1H2	14	1,780		
	100×75	DY1H1	10	1,780		
	125×100	DY1Q1	5	4,394		
	150×100	DY1F2	4	6,251		
90°大曲りエルボ (LL) 	40	DLL40	110	277		
	50	DLL50	56	432		
	65	DLL65	26	718		
	75	DLL75	22	1,003		
	100	DLL1H	10	1,947		
	125	DLL1Q	5	3,483		
	150	DLL1F	4	5,267		
	75×50	DLL752	30	867		
	100×65	DLL1H2	14	1,797		
	100×75	DLL1H1	12	2,014		
	90°大曲り両Y (WLT) 	65	DWT65	10	1,678	
75		DWT75	8	2,516		
100		DWT1H	4	5,032		
100×75		DWT1H1	6	3,252		
125×100		DWT1Q1	3	7,521		
径違い90°エルボ (DL) 	50×40	DDL501	50	499		

13) エスロンDV継手付属品 (排水用硬質ポリ塩化ビニル管継手)









品名	サイズ	品番	梱包数	価格(円/個)	改定	備考
	40	SS40	120	1,023		
	50	SS50	75	1,348		
	65	SS65	40	1,517		
	75	SS75	45	1,889		
	100	SS1H	16	2,154		
	125	SS1Q	12	2,618		
	150	SS1F	6	3,176		
	40	YS40	102	1,223		
	50	YS50	60	1,627		
	65	YS65	28	1,967		
	75	YS75	22	2,354		
	100	YS1H	11	4,554		
	125	YS1Q	6	6,056		
	150	YS1F	4	8,131		
	40	DVS40	200	202	※	
	50	DVS50	180	341		
	65	DVS65	96	481	※	
	75	DVS75	90	651	※	
	100	DVS1H	44	1,223	※	
	50	CO50	90	1,077		
	65	CO65K	40	5,603		
	75	CO75	40	1,617		
	100	CO1HK	18	11,731		
	125	CO1QK	12	12,431		
	150	CO1FK	6	19,596		
	25	NCO25N	200	279	※	
	30	NCO30N	200	295	※	
	40	NCO40N	240	295	※	
	50	NCO50N	132	341	※	
	65	NCO65N	68	573	※	
	75	NCO75N	48	712	※	
	100	NCO1HN	24	1,039	※	
	125	NCO1Q	10	3,579	※	
	150	NCO1F	6	4,941	※	
	100×40	NCO1H4	24	1,886	※	
	150	NJK1F	3	17,898		
	50	VO50	195	538		
	65	VO65	135	606		
	75	VO75	105	674		
	65	VO65B	32	4,094	※	
	75	VO75B	30	4,432	※	
	100	VO1HB	11	5,091		
	125	VO1QB	8	6,222	※	
	65×50×50	DLT611	25	931	※	

※ メーカー規格品です

14) エスロンDV-VU継手 (排水用硬質ポリ塩化ビニル管継手)[AS 38]

品名	サイズ	品番	梱包数	価格(円/個)	改定	備考
	40	UDL40	150	158		
	50	UDL50	85	257		
	65	UDL65	36	443		
	75	UDL75	30	606		
	100	UDL1H	16	1,211		
	125	UDL1Q	8	2,563		
	150	UDL1F	5	4,396		
	50	U4L50	100	232		
	65	U4L65	46	382		
	75	U4L75	40	526		
	100	U4L1H	20	1,022		
	125	U4L1Q	10	2,176		
	150	U4L1F	6	3,572		
	50	ULL50	56	432		
	65	ULL65	26	718		
	75	ULL75	22	1,003		
	100	ULL1H	10	1,947		
	125	ULL1Q	5	3,483		
	150	ULL1F	4	5,267		
	50	UDS50	160	151		
	65	UDS65	74	233		
	75	UDS75	70	376		
	100	UDS1H	34	718		
	125	UDS1Q	14	1,423		
	150	UDS1F	12	2,439		
	50	UDT50	50	392		
	65	UDT65	24	646		
	75	UDT75	24	881		
	100	UDT1H	12	1,820		
	150	UDT1F	4	6,003		
	75×50	UDT752	34	712		
	100×50	UDT1H3	22	1,373		
	100×75	UDT1H1	14	1,373		
	150×100	UDT1F2	6	5,724		
	50	ULT50	34	540		
	75	ULT75	16	1,362		
	100	ULT1H	8	2,638		
	125	ULT1Q	4	4,392		
	150	ULT1F	3	9,137		
	75×50	ULT752	26	1,017		
	100×50	ULT1H3	14	1,958		
	100×75	ULT1H1	12	1,958		
150×125	ULT1F1	3	6,607			
	50	UY50	40	500		
	65	UY65Y	18	819		
	75	UY75	16	1,196		
	100	UY1H	8	2,467		
	150	UY1F	3	10,366		
	75×50	UY752	26	864		
	100×50	UY1H3	16	1,780		
	100×75	UY1H1	10	1,780		
	50×40	UIN501	150	153		
	65×50	UIN651	100	295		
	75×50	UIN752	120	420		
	75×65	UIN751	90	420		
	100×50	UIN1H3	54	589		
	100×65	UIN1H2	54	616		
	100×75	UIN1H1	48	677		
	125×100	UIN1Q1	25	984		
	150×100	UIN1F2	20	1,536		
	150×125	UIN1F1	18	1,961		
	150×100	UINE1F2	15	3,080		
	150×125	UINE1F1	9	3,470		

15) エスロン大口径VU継手 (排水用硬質ポリ塩化ビニル管継手)

品名	サイズ	品番	梱包数	価格(円/個)	改定	備考
 90°エルボ (DL)	200	UDL2HY	4	5,890		
	250	UDL2F	3	12,270		
	300	UDL3H	1	23,180		
	350	UDL3FT	1	61,180	☆	
	400	UDL4HT	1	100,830	☆	
 45°エルボ (45L)	200	U4L2H	3	5,000		
	250	U4L2F	3	10,410		
	300	U4L3H	2	15,400		
	350	U4L3FT	1	58,090	☆	
	400	U4L4HT	1	97,570	☆	
 90°大曲りエルボ (LL)	200	ULL2HY	2	10,050		
	250	ULL2F	2	28,460		
	300	ULL3H	1	46,680		
 ソケット (DS)	200	UDS2H	8	3,380		
	250	UDS2F	2	6,780		
	300	UDS3H	2	11,280		
	350	UDS3F	1	25,250		
	400	UDS4H	1	52,670		
 90°大曲りY (LT)	200	ULT2H	2	21,690		
	250	ULT2F	1	39,510		
	200×100	ULT2H3	2	19,830		
	200×150	ULT2H1	2	20,290		
 45° Y (Y)	200	UY2H	2	20,910		
	200×150	UY2H1	2	20,910		
 インクリーザー (IN)	200×100	UIN2H3	6	3,870		
	200×125	UIN2H2	12	4,090		
	200×150	UIN2H1	12	4,750		
	250×200	UIN2F1	4	9,140		
	300×200	UIN3H2	2	15,500		
	300×250	UIN3H1	2	20,140		
 90°Y (DT)	200	UDT2H	3	11,850		
	250	UDT2F	2	21,320		
	300	UDT3HT	1	48,010	☆	
	350	UDT3FT	1	82,090	☆	
	200×100	UDT2H3	4	8,930		
	200×125	UDT2H2	4	10,470		
	200×150	UDT2H1	2	11,150		
	250×150	UDT2F2	2	22,460		
	250×200	UDT2F1T	1	26,330	☆	
	300×200	UDT3H2T	1	45,700	☆	

16) エスロンVU特殊継手

品名	サイズ	品番	梱包数	価格(円/個)	改定	備考
 VUキャップ	40	VUC40N	480	160		
	50	VUC50N	240	180		
	65	VUC65N	120	380		
	75	VUC75N	100	610		
	100	VUC1HN	48	920		
	125	VUC1QN	30	1,250		
	150	VUC1FN	12	1,550		
	200	VUC2HN	6	2,470		
	250	VUC2F	4	11,810		
	300	VUC3H	3	18,220		
	 VU ソケット	50	USS50N	60	480	
75		USS75N	18	1,010		
100		USS1H	15	1,550		
75×50		USS752	30	1,010		
100×75		USS1H1	20	1,460		
 VU異径90°エルボ	50×40	UDL501Y	80	500		
	75×50	UDL752Y	30	680		
	100×75	UDL1H1	18	1,190		
 90°片受エルボ	50	UKL50Y	75	250		
	75	UKL75	30	580		
	100	UKL1H	15	1,190		
	100P×50S	UKL1H3	30	1,060		
	100P×75S	UKL1H1	20	1,190		
 45°片受エルボ	50	U4KL50Y	75	240		
	75	U4KL75	30	500		
	100	U4KL1H	25	1,010		
	100P×75S	U4KL1H1	30	1,190		
 60°エルボ	75	U6L75	25	1,010		
	100	U6L1H	15	1,630		
 30°エルボ	75	U3L75	30	1,010		
	100	U3L1H	25	1,630		
 22 1/2°エルボ	75	U2L75	30	1,010		
	100	U2L1H	25	1,630		
 11 1/4°エルボ	75	U1L75	30	1,010		
	100	U1L1H	25	1,630		
 パイプ内差 90°エルボ	40	UDIL40	15	230		
	50	UDIL50	35	240		
	75	UDIL75	12	550		
	100	UDIL1H	10	1,140		
 パイプ内差 45°エルボ	40	U4IL40	20	210		
	50	U4IL50	46	230		
	75	U4IL75	16	490		
	100	U4IL1H	14	960		
 持ち出しニップル	40	UMN40	20	740		
	50	UMN50	70	800		
	75	UMN75	24	890		
	100	UMN1H	12	960		

17) エスロン自在継手 (建築設備用自在継手)

品名	サイズ	品番	梱包数	価格(円/個)	改定	備考
自在継手 高上げ高さ90mm以下 高上げ高さ90mm以上	75	F3SR75S	10	7,360		
	75	F3SR75L	10	7,360		
90°片受エルボ 便器継手	75(45°)	CBA75S	10	7,750		
	75(22 1/2")	CBE75S	10	7,750		
	75(11 1/4")	CBF75S	10	7,750		
便器接続媒介継手	75	CBC75S	4	4,020		

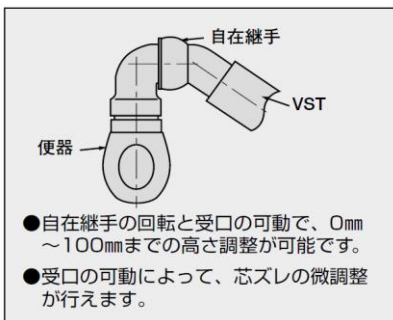













18) エスロン透明DV継手 (排水用硬質ポリ塩化ビニル管継手) [JIS K 6739]

品名	サイズ	品番	梱包数	価格(円/個)	改定	備考
90°エルボ (DL)	30	SDDL30	300	140		
	40	SDDL40	150	189		
	50	SDDL50	85	296		
	65	SDDL65	36	499		
	75	SDDL75	30	674		
	100	SDDL1H	16	1,333		
45°エルボ (45L)	30	SD4L30	340	140		
	40	SD4L40	190	171		
	50	SD4L50	100	257		
	65	SD4L65	46	431		
	75	SD4L75	40	593		
90°大曲りエルボ (LL)	40	SDLL40	110	303		
	50	SDLL50	56	485		
	65	SDLL65	26	795		
	75	SDLL75	22	1,118		
	100	SDLL1H	10	2,142		
ソケット (DS)	30	SDDS30	540	112		
	40	SDDS40	280	125		
	50	SDDS50	160	176		
	65	SDDS65	74	257		
	75	SDDS75	70	431		
	100	SDDS1H	34	795		







品名	サイズ	品番	梱包数	価格(円/個)	改定	備考
45° Y (Y)	40	SDY40	70	382		
	50	SDY50	40	552		
	65	SDY65Y	18	902		
	75	SDY75	16	1,320		
	100	SDY1H	8	2,720		
	50×30	SDY503	70	396		
	50×40	SDY501	50	396		
	65×40	SDY652	30	729		
	65×50	SDY651Y	24	729		
	75×40	SDY753	32	957		
	75×50	SDY752	26	957		
	75×65	SDY751	20	957		
	100×40	SDY1H4	22	1,980		
	100×50	SDY1H3	16	1,980		
100×65	SDY1H2	14	1,980			
100×75	SDY1H1	10	1,980			
90° Y (DT)	30	SDDT30	180	187		
	40	SDDT40	100	271		
	50	SDDT50	50	445		
	65	SDDT65	24	714		
	75	SDDT75	24	970		
	100	SDDT1H	12	2,008		
	40×30	SDDT402	120	222		
	50×30	SDDT503	76	311		
	50×40	SDDT501	66	311		
	65×40	SDDT652	40	560		
	65×50	SDDT651	34	560		
	75×40	SDDT753	34	795		
	75×50	SDDT752	34	795		
	100×50	SDDT1H3	22	1,508		
	100×65	SDDT1H2	16	1,508		
	100×75	SDDT1H1	14	1,508		
	125×100	SDDT1Q1	8	6,129		
	90°大曲りY (LT)	40	SDLT40	70	457	
50		SDLT50	34	606		
65		SDLT65Y	16	1,044		
75		SDLT75	16	1,508		
100		SDLT1H	8	2,910		
50×40		SDLT501	46	538		
65×40		SDLT652	30	783		
65×50		SDLT61Y	22	783		
75×40		SDLT753	30	1,131		
75×50		SDLT752	26	1,131		
75×65		SDLT751	20	1,131		
100×40		SDLT1H4	18	2,155		
100×50	SDLT1H3	14	2,155			
100×65	SDLT1H2	12	2,155			
100×75	SDLT1H1	12	2,155			
インクレーザー (IN)	40×30	SDI401	270	176		
	50×40	SDI501	150	176		
	65×40	SDI652	130	337		
	65×50	SDI651	100	337		
	75×50	SDI752	120	473		
	75×65	SDI751	90	473		
	100×50	SDI1H3	54	755		
径違い90°大曲りY	65×50×50	SDLT611	25	1,024		
排水用バルブソケット	50	SDVS50	180	375		

19) エスロン透明DV-VU継手 (排水用硬質ポリ塩化ビニル管継手)

品名	サイズ	品番	梱包数	価格(円/個)	改定	備考
90°エルボ (VUDL) 	40	SUDL40	150	200		
	50	SUDL50	85	300		
	65	SUDL65	36	500		
	75	SUDL75	30	680		
	100	SUDL1H	16	1,330		
45°エルボ (VU45L) 	50	SU4L50	100	250		
	65	SU4L65	46	430		
	75	SU4L75	40	590		
	100	SU4L1H	20	1,130		
90°大曲りエルボ (VULL) 	50	SULL50	56	490		
	65	SULL65	26	800		
	75	SULL75	22	1,120		
	100	SULL1H	10	2,140		
	125	SULL1Q	5	3,840		
ソケット (VUDS) 	50	SUDS50	160	180		
	65	SUDS65	74	250		
	75	SUDS75	70	430		
	100	SUDS1H	34	800		
	125	SUDS1Q	14	1,580		
45°Y (VUY) 	50	SUY50	40	550		
	65	SUY65Y	18	900		
	75	SUY75	16	1,310		
	100	SUY1H	8	2,710		
	100×50	SUY1H3	16	1,970		
100×75	SUY1H1	10	1,970			
90°大曲りY (VULT) 	50	SULT50	34	600		
	75	SULT75	16	1,520		
	100	SULT1H	8	2,920		
	75×50	SULT752	26	1,130		
	100×50	SULT1H3	14	2,160		
	100×75	SULT1H1	12	2,160		
90°Y (VUDT) 	50	SUDT50	50	460		
	65	SUDT65	24	720		
	75	SUDT75	24	980		
	100	SUDT1H	12	2,000		
	75×50	SUDT752	34	800		
	100×50	SUDT1H3	22	1,530		
	100×75	SUDT1H1	14	1,530		
	150×100	SUDT1F2	6	8,960		
インクリーザー (VUIN) 	50×40	SUIN501	150	180		
	65×50	SUIN651	100	340		
	75×50	SUIN752	120	480		
	75×65	SUIN751	90	480		
	100×50	SUIN1H3	54	760		
	100×75	SUIN1H1	48	760		
偏心インクリーザー (VUINE) 	75×50	SUIE72Y	50	1,550		
ソケット (VUSS) 	50	SUSS50Y	60	540		
	75	SUSS75Y	18	1,110		
	100	SUSS1H	15	1,710		
90°片受エルボ 	50	SUKL50Y	75	280		
45°片受エルボ 	75	SU4KL75	30	560		

品名	サイズ	品番	梱包数	価格(円/個)	改定	備考
異径90°エルボ (VUDL) 	50×40	SUDL51Y	80	590		
	75×50	SUDL72Y	30	810		
	100×75	SUDL1H1	18	1,420		



20) エスロンDVカラー継手(シルバー) (排水用硬質ポリ塩化ビニル管継手)
[JIS K 6739]

品名	サイズ	品番	梱包数	価格(円/個)	改定	備考
90°エルボ (DL) 	40	JDDL40	150	280	☆	※
	50	JDDL50	85	440	☆	※
	65	JDDL65	36	740	☆	※
	75	JDDL75	30	1,010	☆	※
	100	JDDL1H	16	1,980	☆	※
	125	JDDL1Q	8	4,230	☆	※
	150	JDDL1F	5	7,200	☆	※
45°エルボ (45L) 	40	JD4L40	190	280	☆	※
	50	JD4L50	100	380	☆	※
	65	JD4L65	46	650	☆	※
	75	JD4L75	40	890	☆	※
	100	JD4L1H	20	1,710	☆	※
	125	JD4L1Q	10	3,580	☆	※
150	JD4L1F	6	5,860	☆	※	
ソケット (DS) 	40	JDDS40	280	220	☆	※
	50	JDDS50	160	280	☆	※
	65	JDDS65	74	400	☆	※
	75	JDDS75	70	650	☆	※
	100	JDDS1H	34	1,190	☆	※
	125	JDDS1Q	14	2,350	☆	※
	150	JDDS1F	12	4,010	☆	※
インクリーザー (IN) 	40×30	JDIN402	270	250	☆	※
	50×40	JDIN501	150	280	☆	※
	65×50	JDIN651	100	510	☆	※
	75×50	JDIN752	120	690	☆	※
	75×65	JDIN751	90	690	☆	※
	100×50	JDIN1H3	54	980	☆	※
	100×65	JDIN1H2	54	1,020	☆	※
	100×75	JDIN1H1	48	1,120	☆	※
	125×100	JDIN1Q1	25	1,630	☆	※
90°大曲りエルボ (LL) 	40	JDLL40	110	480	☆	※
	50	JDLL50	56	730	☆	※
	65	JDLL65	26	1,190	☆	※
	75	JDLL75	22	1,650	☆	※
	100	JDLL1H	10	3,200	☆	※
	125	JDLL1Q	5	5,730	☆	※
	150	JDLL1F	4	8,640	☆	※
	75×50	JDLL752	30	1,890	☆	※
	100×65	JDLL1H2	14	3,330	☆	※
	100×75	JDLL1H1	12	3,800	☆	※
90°大曲りY (LT) 	40	JDLT40	70	690	☆	※
	50	JDLT50	34	900	☆	※
	75	JDLT75	16	2,260	☆	※
	100	JDLT1H	8	4,340	☆	※
	50×40	JDLT501	46	810	☆	※
	65×50	JDLT61Y	22	1,180	☆	※
	75×50	JDLT752	26	1,680	☆	※
	75×65	JDLT751	20	1,680	☆	※
	100×50	JDLT1H3	14	3,210	☆	※
	100×65	JDLT1H2	12	3,210	☆	※
	100×75	JDLT1H1	12	3,210	☆	※
	125×65	JDLT1Q3	6	6,760	☆	※
	125×75	JDLT1Q2	6	6,760	☆	※
	125×100	JDLT1Q1	4	6,760	☆	※
	150×75	JDLT1F3	5	10,830	☆	※
150×100	JDLT1F2	4	10,830	☆	※	
150×125	JDLT1F1	3	10,830	☆	※	

※ マンセルNo.

シルバー :5.6Y 6.8/1.2

20) エスロンDVカラー継手(シルバー) (排水用硬質ポリ塩化ビニル管継手)
[JIS K 6739]

品名	サイズ	品番	梱包数	価格(円/個)	改定	備考
90° Y (DT) 	40	JDDT40	100	430	☆	
	50	JDDT50	50	660	☆	
	65	JDDT65	24	1,060	☆	
	75	JDDT75	24	1,470	☆	
	100	JDDT1H	12	2,990	☆	
	125	JDDT1Q	6	5,510	☆	
	150	JDDT1F	4	10,790	☆	
	50×40	JDDT501	66	480	☆	
	65×40	JDDT652	40	870	☆	
	65×50	JDDT651	34	870	☆	
	75×40	JDDT753	34	1,180	☆	
	75×50	JDDT752	34	1,180	☆	
	75×65	JDDT751	30	1,180	☆	
	100×40	JDDT1H4	24	2,270	☆	
	100×50	JDDT1H3	22	2,270	☆	
	100×65	JDDT1H2	16	2,270	☆	
	100×75	JDDT1H1	14	2,270	☆	
125×75	JDDT1Q2	8	4,980	☆		
125×100	JDDT1Q1	8	4,980	☆		
45° Y (Y) 	40	JDY40	70	580	☆	
	50	JDY50	40	840	☆	
	65	JDY65Y	18	1,350	☆	
	75	JDY75	16	1,970	☆	
	100	JDY1H	8	4,040	☆	
	150	JDY1F	3	16,970	☆	
	50×40	JDY501	50	590	☆	
	65×40	JDY652	30	1,110	☆	
	65×50	JDY651Y	24	1,110	☆	
	75×40	JDY753	32	1,420	☆	
	75×50	JDY752	26	1,420	☆	
	75×65	JDY751	20	1,420	☆	
	100×50	JDY1H3	16	2,940	☆	
	100×65	JDY1H2	14	2,940	☆	
	100×75	JDY1H1	10	2,940	☆	
	125×100	JDY1Q1	5	7,250	☆	
	150×100	JDY1F2	4	10,240	☆	





21) エスロンDVカラー継手(シルバー) (排水用硬質ポリ塩化ビニル管継手)

品名	サイズ	品番	梱包数	価格(円/個)	改定	備考
差込ソケット (ES) 	40	JSS40	120	2,180	☆	
	50	JSS50	75	2,940	☆	
	65	JSS65	40	3,290	☆	
	75	JSS75	45	4,110	☆	
	100	JSS1H	16	4,560	☆	
	125	JSS1Q	12	5,560	☆	
やりとりソケット (LES) 	150	JSS1F	6	6,730	☆	
	65	JYS65	28	4,240	☆	
	75	JYS75	22	5,110	☆	
	100	JYS1H	11	9,810	☆	
フランジ型掃除口 (CO) 	125	JYS1Q	6	13,050	☆	
	150	JYS1F	4	17,580	☆	
	50	JCO50	90	1,760	☆	
	65	JCO65K	40	9,530	☆	
フランジ型掃除口 (CO) 	75	JCO75	40	3,510	☆	
	100	JCO1HK	18	25,190	☆	
	125	JCO1QK	12	26,820	☆	
	150	JCO1FK	6	28,430	☆	
排水用バルブソケット (VS) 	50	JDVS50	180	590	☆	

品名	サイズ	品番	梱包数	価格(円/個)	改定	備考
通気口 (VO) Aタイプ 	50	JVO50	195	1,450	☆	
	65	JVO65	135	1,880	☆	
	75	JVO75	105	1,860	☆	
通気口 (VO) Bタイプ 	65	JVO65B	32	6,740	☆	※
	75	JVO75B	30	7,300	☆	※
	100	JVO1HB	11	8,350	☆	※
	125	JVO1QB	8	10,030	☆	※
ねじ式掃除口 (NCO) 	25	JNCO25N	200	550	☆	※
	30	JNCO30N	200	590	☆	※
	40	JNCO40N	240	590	☆	※
	50	JNCO50N	132	680	☆	※
	65	JNCO65N	68	1,130	☆	※
	75	JNCO75N	48	1,680	☆	※
	100	JNCO1HN	24	2,430	☆	※
VUSソケット (SS) 	75	JUSS75Y	18	1,650	☆	※
	100	JUSS1H	15	2,560	☆	※
掃除口付大曲90° Y (COLT) 右 	150×100	JLT1F2R	3	13,740	☆	
	150×125	JLT1F1R	3	27,470	☆	※
掃除口付大曲90° Y (COLT) 左 	150×100	JLT1F2L	3	13,740	☆	
	150×125	JLT1F1L	3	27,470	☆	※
伸縮継手 (NJK) 	150	NJK1FJ	3	32,480	☆	

※ メーカー規格品です

22) エスロンDVココア継手 (排水用硬質ポリ塩化ビニル管継手) [JIS K 6739]

品名	サイズ	品番	梱包数	価格(円/個)	改定	備考
90°エルボ (DL) 	50	DDL50E	42	440	☆	
	65	DDL65E	18	740	☆	
	75	DDL75E	30	1,010	☆	
	100	DDL1HE	16	1,980	☆	
	125	DDL1QE	8	4,230	☆	
45°エルボ (45L) 	50	D4L50E	50	380	☆	
	65	D4L65E	23	650	☆	
	75	D4L75E	40	890	☆	
	100	D4L1HE	20	1,710	☆	
ソケット (DS) 	125	D4L1QE	10	3,580	☆	
	50	DDS50E	80	280	☆	
	65	DDS65E	37	400	☆	
	75	DDS75E	70	650	☆	
	100	DDS1HE	34	1,190	☆	
差込ソケット (ES) 	125	DDS1QE	14	2,350	☆	
	65	SS65E	40	3,290	☆	
	75	SS75E	45	4,110	☆	
	100	SS1HE	16	4,560	☆	
	125	SS1QE	12	5,560	☆	

22) エスロンDVコア継手 (排水用硬質ポリ塩化ビニル管継手) [JIS K 6739]

品名	サイズ	品番	梱包数	価格(円/個)	改定	備考
90°Y (DT) 	50	DDT50E	50	660	☆	
	65	DDT65E	24	1,060	☆	
	75	DDT75E	24	1,470	☆	
	100	DDT1HE	12	2,990	☆	
	125	DDT1QE	6	5,510	☆	
	65×50	DDT65IE	34	870	☆	
	75×50	DDT75IE	34	1,180	☆	
	75×65	DDT75IE	30	1,180	☆	
	100×50	DDT1H3E	22	2,270	☆	
	100×65	DDT1H2E	16	2,270	☆	
	100×75	DDT1H1E	14	2,270	☆	
	125×75	DDT1Q2E	8	4,980	☆	
	125×100	DDT1Q1E	8	4,980	☆	
インクリーザー (IN) 	75×50	DIN752E	120	690	☆	
	100×50	DIN1H3E	54	980	☆	
	100×75	DIN1H1E	48	1,120	☆	
	125×100	DIN1Q1E	25	1,630	☆	
90°大曲りY (LT) 	75×50	DLT752E	26	1,680	☆	
	125×75	DLT1Q2E	6	6,760	☆	
	125×100	DLT1Q1E	4	6,760	☆	
ねじ式掃除口 (NCO) 	65	NCO65EN	68	1,130	☆	※
	75	NCO75EN	48	1,680	☆	※
	100	NCO1HEN	24	2,430	☆	※
	125	NCO1QE	10	7,620	☆	※
VUSソケット (SS) 	75	USS75EY	18	1,650	☆	※
	100	USS1HE	15	2,560	☆	※

※ メーカー規格品です

23) エスロン接着剤

品名	サイズ	品番	梱包数	価格(円/缶)	改定	備考
NO. 73S 	500g	S735G	40	1,640		
	1kg	S731	24	3,260		
NO. 75S 	500g	S755G	40	1,640		
	1kg	S751	24	3,260		
NO. 70S 	500g	S705G	40	1,780		
	1kg	S701	24	3,260		
NO. 80S (HI・ゴールド+用) 	500g	S805G	40	2,090		
	1kg	S801	24	4,160		
NO. 83Sホワイト (HI継手透明ブルー用) 	500g	S835G	40	2,300		
	1kg	S831	24	4,580		
NO. 73Sブルー (排水・通気管用) 	500g	S735GB	40	1,950		
	1kg	S731B	24	3,870		

品名	サイズ	品番	梱包数	価格(円/缶)	改定	備考
NO. 75Sブルー-N (低粘度 排水・通気管用) 	500g	S755GB	40	1,950		
	1kg	S751B	24	3,870		
NO. 73S UV 	500g	S735UV	40	3,840		
NO. 20S 【超速乾】 短時間養生型 	500g	S205G	40	3,690		
NO. 20Sホワイト 【超速乾】 短時間養生型 	500g	S205GW	40	4,060		
NO. 73S バイオレット 	500g	S735GV	40	3,490		
	1kg	S731V	24	6,960		

24) エスロン滑剤

品名	サイズ	品番	梱包数	価格(円/缶)	改定	備考
バルソープ 	1kg(ハケ付)	BSP1H	4	2,890		
	2kg	BSP2	2	3,950		
滑剤No. 1 (差込ソケット用) 	1kg	KZ11	10	2,900		
	2kg	KZ12	6	4,340		

エスロン 硬質塩化ビニル管用着色接着剤

No.73Sバイオレット



軟質塩ビシート
表面への
染み出し対策品

(一社)日本インテリア協会プラスチック床材部会推奨・
床材汚染対策用接着剤

25) エスロン基礎貫通キット (住宅の品質確保促進法対応 戸建住宅新排水システム)

■ 通常セット

品名	品番	梱包数	価格 (円/セット)	改定	セット内容				備考	
					スリーブバンド		排水可とう管	コーキング材		スリーブホルダー
					内管	H寸 (mm)	L寸 (mm)			
エスロン基礎貫通キット 排水用 	YD5SSF	9	14,220		排水可とう管 50	230	580	パッキン	2個	
	YD5SKF	9	14,400			280	580			
	YD5SEF	9	14,400			280	420			
	YD5SN	9	14,640			300	630			
	YD5FSF	3	16,590		430	730				
	YD7SSF	6	19,110		排水可とう管 75	230	580			
	YD7SKF	6	19,280			280	580			
	YD7SEF	6	19,280			280	470			
	YD7SN	6	19,520			325	670			
	YD7FSF	3	21,550		430	730				
	YDHSSF	4	26,230		排水可とう管 100	250	700			
	YDHSEF	4	26,230			300	540			
	YDHSKF	4	26,840			300	700			
	YDHFSF	2	41,480			600	900			
エスロン基礎貫通キット 給水・給湯用 	YDKSSF	9	2,930		PEX SMTX	230	—	テープ	2個	※
	YDBBH	9	3,170			270	—			※
	YDKFSFK	3	4,390			430	—			※

※ PEX: エスロペックス(架橋ポリエチレン管)、SMTX: スーパーエスロメタックス(金属強化ポリエチレン管)

■ 防蟻セット

品名	品番	梱包数	価格 (円/セット)	改定	セット内容					備考	
					スリーブバンド		排水可とう管	コーキング材	防蟻部材		スリーブホルダー
					内管	H寸 (mm)	L寸 (mm)				
エスロン基礎貫通キット 排水用 	YD5SSFB	9	16,670		排水可とう管 50	230	580	防蟻 パッキン	防蟻 テープ	2個	
	YD5SKFB	9	16,840			280	580				
	YD7SSFB	6	21,550		排水可とう管 75	230	580				
	YD7SKFB	6	21,710			280	580				
エスロン基礎貫通キット 給水・給湯用 	YDKSSFB	9	4,390		PEX SMTX	230	—	テープ	防蟻 シーラー	2個	

※ PEX: エスロペックス(架橋ポリエチレン管)、SMTX: スーパーエスロメタックス(金属強化ポリエチレン管)

※ 防蟻シーラーは別売になります

■ 給水・給湯用防蟻シーラー ※コシブプレザービング社製

品名	内容量	品番	梱包数	価格 (円/本)	改定	備考
コシシーラー	320ml/本	YDSCB	10	7,320		

防蟻処理施工、及び5年間保証につきましては、(株)コシブプレザービング様にご相談ください。
 連絡先 株式会社コシブプレザービング
 〒559-0026 大阪市住之江区平林北2-9-145
 TEL: 06-6685-1911

26) エスロン雑排水専用合流継手

品名	サイズ	品番	梱包数	価格 (円/個)	改定	備考
雑排水専用合流継手 	下流: 75、 上流: 50 × 3口	DHC753	1	8,500		





給湯用硬質ポリ塩化ビニル管・継手

1) エスロンHTパイプ (耐熱性硬質ポリ塩化ビニル管) [JIS K 6776]

品名	サイズ	品番	梱包数	価格(円/本)	改定	備考
HTパイプ 長さ: 4m/本 	13	HT134	30	1,610		
	16	HT164	25	2,390		
	20	HT204	20	2,880		
	25	HT254	15	4,170		
	30	HT304	12	5,150		
	40	HT404	8	7,520		
	50	HT504	6	11,490		
	65	HT654	4	15,690		※
	75	HT754	3	22,200		※
	100	HT1H4	2	34,440		※
	125	HT1Q4	1	46,110		※
	150	HT1F4	1	63,180		※

※ メーカー規格品です

2) エスロンHT継手 (耐熱性硬質ポリ塩化ビニル管用継手) [JIS K 6777]

品名	サイズ	品番	梱包数	価格(円/個)	改定	備考	
ソケット 	13	THS13	160	156			
	16	THS16	80	206			
	20	THS20	50	364			
	25	THS25	30	498			
	30	THS30	40	563			
	40	THS40	30	895			
	50	THS50	17	1,421			
	65	THS65	30	2,114		※	
	75	THS75	18	3,056		※	
	100	THS1H	8	6,868		※	
	125	THS1QY	8	10,130		※	
	150	THS1FY	4	14,826		※	
	チーズ 	13	THT13	70	274		
		16	THT16	40	371		
20		THT20	25	601			
25		THT25	15	874			
30		THT30	20	1,071			
40		THT40	12	1,865			
50		THT50	8	2,877			
65		THT65Y	10	5,160		※	
75		THT75Y	8	7,178		※	
100		THT1HY	3	15,350		※	
125		THT1QY	3	26,412		※	
150		THT1FY	2	35,424		※	
90°エルボ 	13	THL13	100	232			
	16	THL16	60	328			
	20	THL20	40	429			
	25	THL25	25	604			
	30	THL30	15	762			
	40	THL40	20	1,219			
	50	THL50	10	2,061			
	65	THL65Y	18	3,295		※	
	75	THL75Y	12	4,940		※	
	100	THL1HY	5	9,944		※	
	125	THL1QY	4	20,508		※	
	150	THL1FY	3	31,379		※	
径違いソケット (A-I形) 	16 × 13	THS161	100	172			
	20 × 13	THS202	70	258			
	20 × 16	THS201	55	258			
	25 × 13	THS253	40	420			
	25 × 16	THS252	40	420			
	25 × 20	THS251	35	420			
	30 × 20	THS302	60	498			
	30 × 25	THS301	50	498			
	40 × 20	THS404	45	813			
	40 × 25	THS403	45	813			
	40 × 30	THS402	45	813			
	50 × 25	THS504	20	1,352			
	50 × 30	THS503	20	1,352			
	50 × 40	THS501	20	1,352			

※ メーカー規格品です

品名	サイズ	品番	梱包数	価格(円/個)	改定	備考
	ソケット呼び/ブッシュ呼び					
径違いソケット・ブッシュ兼用型 (A-II形) ※ 	50 × 13 / 65 × 13	HTS506Y	30	1,352		
	50 × 16 / 65 × 16	HTS505Y	30	1,352		
	50 × 20 / 65 × 20	HTS504Y	30	1,352		
	50 × 25 / 65 × 25	HTS503Y	30	1,352		
	50 × 30 / 65 × 30	HTS502Y	30	1,352		
	50 × 40 / 65 × 40	HTS501Y	30	1,352		
	50 × 50 / 65 × 50	HTS500Y	30	1,352		
	65 × 20 / 75 × 20	HTS655Y	18	2,013		
	65 × 25 / 75 × 25	HTS654Y	18	2,013		
	65 × 30 / 75 × 30	HTS653Y	18	2,013		
	65 × 40 / 75 × 40	HTS652Y	18	2,013		
	65 × 50 / 75 × 50	HTS651Y	18	2,013		
	65 × 65 / 75 × 65	HTS650Y	18	2,013		







※ メーカー規格品です

品名	サイズ	品番	梱包数	価格(円/個)	改定	備考
径違いソケット (A-III形) 	75 × 20	HTS756Y	16	2,910		※
	75 × 25	HTS755Y	16	2,910		※
	75 × 30	HTS754Y	16	2,910		※
	75 × 40	HTS753Y	16	2,910		※
	75 × 50	HTS752Y	16	2,910		※
	75 × 65	HTS751Y	16	2,910		※
	75 × 75	HTS750Y	12	2,910		※
	100 × 20	HTS1H7Y	4	6,540		※
	100 × 25	HTS1H6Y	4	6,540		※
	100 × 50	HTS1H3Y	4	6,540		※
	100 × 65	HTS1H2Y	4	6,540		※
	100 × 75	HTS1H1Y	4	6,540		※
	100 × 100	HTS1H0Y	4	6,540		※
	125 × 20	HTS1Q8Y	4	9,647		※
	125 × 25	HTS1Q7Y	4	9,647		※
125 × 75	HTS1Q2Y	4	9,647		※	
125 × 100	HTS1Q1Y	4	9,647		※	
125 × 125	HTS1Q0Y	4	9,647		※	
組合せ径違いソケット 	150 × 125	HTS1F1	4	14,114		※
キャップ 	13	THC13	280	156		
	16	THC16	180	187		
	20	THC20	75	235		
	25	THC25	45	355		
	30	THC30	70	434		
	40	THC40	52	590		
45°エルボ 	13	TH4L13	100	229		※
	16	TH4L16	70	284		※
	20	TH4L20	35	310		※
	25	TH4L25	25	498		※
	30	TH4L30	15	565		※
	40	TH4L40	25	1,009		※
	50	TH4L50	12	1,749		※
	65	TH4L65Y	12	2,960		※
	75	TH4L75	8	4,439		※
	100	TH4L1H	4	7,936		※

※ メーカー規格品です

2) エスロンHT継手 (耐熱性硬質ポリ塩化ビニル管用継手) [JIS K 6777]

品名	サイズ	品番	梱包数	価格(円/個)	改定	備考
径違いチース 	16 × 13	THT161	60	335		
	20 × 13	THT202	35	442		
	20 × 16	THT201	30	442		
	25 × 13	THT253	20	623		
	25 × 16	THT252	20	623		
	25 × 20	THT251	17	623		
	30 × 13	THT304A	36	778		
	30 × 16	THT303A	36	778		
	30 × 20	THT302A	36	778		
	30 × 25	THT301A	30	778		
	40 × 13	THT406A	25	1,833		
	40 × 16	THT405A	26	1,833		
	40 × 20	THT404A	20	1,833		
	40 × 25	THT403A	20	1,833		
	40 × 30	THT402A	18	1,833		
	50 × 13	THT507A	18	2,872		
	50 × 16	THT506A	16	2,872		
	50 × 20	THT505A	14	2,872		
	50 × 25	THT504A	12	2,872		
	50 × 30	THT503A	12	2,872		
50 × 40	THT502A	10	2,872			
組合わせチース 	65 × 13	HTT657	10	4,942	※	
	65 × 16	HTT656	10	4,942	※	
	65 × 20	HTT655	10	4,942	※	
	65 × 25	HTT654	10	4,942	※	
	65 × 30	HTT653	10	4,942	※	
	65 × 40	HTT652	10	4,942	※	
	65 × 50	HTT651	10	4,942	※	
	75 × 20	HTT756	10	7,250	※	
	75 × 25	HTT755	10	7,250	※	
	75 × 30	HTT754	10	7,250	※	
	75 × 40	HTT753	10	7,250	※	
	75 × 50	HTT752	10	7,250	※	
	75 × 65	HTT751	10	7,250	※	
	100 × 20	HTT1H8	3	14,616	※	
	100 × 25	HTT1H7	3	14,616	※	
	100 × 30	HTT1H6	3	14,616	※	
	100 × 40	HTT1H4	3	14,616	※	
	100 × 50	HTT1H3	3	14,616	※	
	100 × 65	HTT1H2	3	14,616	※	
	100 × 75	HTT1H1	3	14,616	※	
	125 × 20	HTT1Q8	3	25,158	※	
	125 × 25	HTT1Q7	3	25,158	※	
	125 × 50	HTT1Q4	3	25,158	※	
	125 × 65	HTT1Q3	3	25,158	※	
	125 × 75	HTT1Q2	3	25,158	※	
125 × 100	HTT1Q1	3	25,158	※		
150 × 20	HTT1F9	2	33,737	※		
150 × 25	HTT1F8	2	33,737	※		
150 × 75	HTT1F3	2	33,737	※		
150 × 100	HTT1F2	2	33,737	※		
150 × 125	HTT1F1	2	33,737	※		
インサート 給水栓ソケット 	13 × Rp1/2	TIWS13M	100	750	☆	
	16 × Rp1/2	TIWS16M	90	980	☆	
	20 × Rp1/2	TIWS22M	60	1,310	☆	※
	20 × Rp3/4	TIWS20M	50	1,310	☆	
	25 × Rp1	TIWS25M	30	2,100	☆	
インサート 給水栓エルボ 	13 × Rp1/2	TIWL13M	90	940	☆	
	16 × Rp1/2	TIWL16M	70	1,270	☆	
	20 × Rp1/2	TIWL22M	45	1,530	☆	※
	20 × Rp3/4	TIWL20M	40	1,540	☆	
	25 × Rp1	TIWL25M	25	2,310	☆	
インサート 首長給水栓エルボ 	13 × Rp1/2	TIL13LM	70	940	☆	※













品名	サイズ	品番	梱包数	価格(円/個)	改定	備考
インサート 給水栓チース 	13 × Rp1/2	TIWT13M	60	1,120	☆	※
インサート バルブソケット 	13 × R1/2	TIVS13M	80	1,610	☆	
	16 × R1/2	TIVS16M	60	1,820	☆	
	20 × R3/4	TIVS20M	40	2,760	☆	
	25 × R1	TIVS25M	25	3,550	☆	
	30 × R1 1/4	TIVS30M	24	5,730	☆	
	40 × R1 1/2	TIVS40M	20	6,620	☆	
	50 × R2	TIVS50M	15	12,870	☆	
90°バンド 	13	TH9B13N	100	232		
	16	TH9B16N	100	328		
	20	TH9B20N	50	429		
	25	TH9B25N	50	604		
	30	TH9B30N	50	1,242		
	40	TH9B40N	50	1,778		
	50	TH9B50N	30	2,903		
	65	TH9B65	15	5,042		※
	75	TH9B75	5	8,700		※
	100	TH9B1H	3	12,500		※
	125	TH9B1Q	2	22,370		※
	150	TH9B1F	2	44,750		※
45°バンド 	13	TH4B13N	100	232		
	16	TH4B16N	100	328		
	20	TH4B20N	50	429		
	25	TH4B25N	50	604		
	30	TH4B30N	50	1,079		
	40	TH4B40N	50	1,431		
	50	TH4B50N	50	2,268		
	65	TH4B65	10	4,963		※
	75	TH4B75	5	6,463		※
	100	TH4B1H	5	11,300		※
	125	TH4B1Q	2	21,600		※
	150	TH4B1F	2	38,540		※
22 1/2°バンド 	13	TH2B13N	100	232		
	16	TH2B16N	100	328		
	20	TH2B20N	50	429		
	25	TH2B25N	50	604		
	30	TH2B30N	50	911		
	40	TH2B40N	50	1,119		
	50	TH2B50N	50	1,687		
	65	TH2B65	12	2,954		※
	75	TH2B75	10	4,940		※
	100	TH2B1H	5	9,140		※
	125	TH2B1Q	3	16,340		※
	150	TH2B1F	2	25,480		※
11 1/4°バンド 	13	TH1B13N	100	232		
	16	TH1B16N	100	328		
	20	TH1B20N	50	429		
	25	TH1B25N	50	604		
	30	TH1B30N	50	911		
	40	TH1B40N	50	1,119		
	50	TH1B50N	50	1,687		
	65	TH1B65	12	2,954		※
75	TH1B75	10	4,940		※	
	100	TH1B1H	5	9,140		※
	125	TH1B1Q	3	13,670		※
	150	TH1B1F	2	22,680		※
温泉用排水 バルブソケット 	50 × R2	THVS50	44	1,997		※

※ メーカー規格品です











2) エスロンHT継手 (耐熱性硬質ポリ塩化ビニル管用継手) [JIS K 6777]

品名	サイズ	品番	梱包数	価格(円/個)	改定	備考
伸縮継手 B型(ループ型) 	13	THEX13N	50	1,287		
	16	THEX16N	50	1,728		
	20	THEX20N	30	2,407		
	25	THEX25N	20	3,035		
	30	THEX30N	10	3,765		
	40	THEX40N	5	6,185		
伸縮継手 U型 	50	THEX50N	4	8,451		
	65	THEX65	2	17,080		※
	75	THEX75	2	29,210		※
	100	THEX1H	2	59,040		※

3) エスロンHTDV継手 (排水用耐熱性硬質ポリ塩化ビニル管継手)

品名	サイズ	品番	梱包数	価格(円/個)	改定	備考
ソケット 	20	HEDS20M	150	135		
	25	HEDS25M	120	188		
	40	HEDS40M	45	203		
	50	HEDS50M	24	215		
90°エルボ 	20	HEDL20M	100	161		
	25	HEDL25M	70	229		
	40	HEDL40	60	269		
	50	HEDL50	30	323		
	50×40	HEDL501	40	350		
90°大曲りエルボ 	50	HELL50	20	458		
45°エルボ 	40	HE4L40	60	269		
	50	HE4L50	30	296		
90°Y 	40	HEDT40	40	471		
	50	HEDT50	20	538		
	50×40	HEDT501	25	511		
排水用 バルブソケット 	40	HEVS40M	54	269		
	50	HEVS50M	33	376		
90°大曲りY 	40	HELT40	30	606		
	50	HELT50	15	780		
	50×40	HELT501	20	699		
インクリーザー 	50×40	HEIN51M	30	538		
差込ソケット 	40	HESS40M	22	1,184		
	50	HESS50	18	1,305		
ねじ式掃除口 	40	HECO40M	50	552		
	50	HECO50M	32	565		
	75	HECO75	20	4,047		
	100	HECO1H	12	6,807		
DT-R 	50	HEDTR50	9	1,844		
耐熱排水トラップ 	50	HETR50	18	5,380		
食器洗浄機用チース 	50×20	HTDV504	30	484		
	50×25	HTDV503	25	525		

4) エスロン透明HTDV継手 (排水用耐熱性硬質ポリ塩化ビニル管継手)

品名	サイズ	品番	梱包数	価格(円/個)	改定	備考
ソケット 	20	HDS20SM	150	161		
	25	HDS25SM	120	215		
	40	HDS40SM	45	243		
	50	HDS50SM	24	269		
	75	HDS75S	30	1,369		
	100	HDS1HS	14	2,399		
90°エルボ 	20	HDL20SM	100	188		
	25	HDL25SM	70	256		
	40	HDL40S	60	310		
	50	HDL50S	30	376		
	50×40	HDL501S	40	403		
	75	HDL75S	16	2,234		
	100	HDL1HS	7	4,059		
90°大曲りエルボ 	50	HLL50S	20	538		
	75	HLL75S	11	3,321		
	100	HLL1HS	5	6,527		
45°エルボ 	40	H4L40S	60	310		
	50	H4L50S	30	350		
	75	H4L75S	20	1,954		
	100	H4L1HS	8	3,427		
90°Y 	40	HDT40S	40	538		
	50	HDT50S	20	618		
	50×40	HDT501S	25	591		
	75	HDT75S	12	2,947		
	100	HDT1HS	5	5,650		
排水用バルブソケット 	40	HVS40SM	54	310		
	50	HVS50SM	33	431		
90°大曲りY 	40	HLT40S	30	699		
	50	HLT50S	15	888		
	50×40	HLT501S	20	807		
	75	HLT75S	8	3,789		
	75×50	HLT752S	8	2,843		
	100	HLT1HS	4	8,842		
	100×75	HLT1H1S	4	6,527		
インクリーザー 	50×40	HIN51SM	30	606		
	75×50	HIN752S	20	1,122		
	100×75	HIN1H1S	14	2,269		
伸縮継手 	75	HSS75S	8	8,211		
	100	HSS1HS	6	10,843		
食器洗浄機用チース 	50×20	HVD504S	30	565		
	50×25	HVD503S	25	606		

5) エスロンHTDV-VU継手 (食器洗浄機排水継手)

品名	サイズ	品番	梱包数	価格(円/個)	改定	備考
HTDV-VU継手 	50×20	HTVU504	30	618		※
	50×25	HTVU503	25	780		※

※ 20・25側はDV受口、50側はDV-VU受口仕様です

6) 食器洗浄機用耐熱排水配管セット

品名	サイズ	品番	梱包数	価格(円/個)	改定	備考
食器洗浄機用耐熱排水配管セット (戸建て住宅用)	50×20	HTDHS20	5	3,390		※

※ 同梱内容

- HTパイプ 呼び径20(1m): 2本
- HTDV-VU継手 食器洗浄機用チース呼び径50×20: 1個
- 透明HTDV継手 90°エルボ呼び径20: 4個

7) 耐熱ストレーナー付ホッパー

品名	サイズ	品番	梱包数	価格(円/個)	改定	備考
耐熱ストレーナー付ホッパー 	50	HESH50	20	1,230		

8) HT接着剤

品名	サイズ	品番	梱包数	価格(円/缶)	改定	備考
HT接着剤 (No.100S) 	250g	S1H2G	80	1,810		
	500g	S1H5G	40	3,630		
HT接着剤 (No.100Sグリーン) 	500g	S1H5GG	40	3,780		

9) 滑剤 (DT-R及び差込ソケット用)

品名	サイズ	品番	梱包数	価格(円/缶)	改定	備考
滑剤 (No.1) 	1kg	KZ11	10	2,900		
	2kg	KZ12	6	4,340		

SEKISUI

環境・ライフラインカンパニー

エスロンタイムズ
<https://eslontimes.com>



二次元コードで
アクセスは
コララ!

専用の管理ページでさらに便利に!
あなただけのエスロンタイムズ

MYエスロン®

*記載価格はメーカー希望標準設計価格です。
*価格には消費税は含まれておりません。
*記載価格は2026年5月20日からの価格です。
*本価格表の記載事項は予告なく変更する場合があります。

不許転載

2026年 5月 改訂1版-0刷

建築設備用エスロンパイプ
設計積算価格表

積水化学工業株式会社
給排水インフラ事業部

ツールコード

No. 05663

2026.5.0TH TX